

**ANTIVIBRANTI
ANTISISMICI**

**SEISMIC RESTRAINT
ANTI-VIBRATION MOUNTS**

PER SCEGLIERE IL SUPPORTO ANTIVIBRANTE CORRETTO BISOGNA CONOSCERE:

1. **PESO STATICO** della macchina e **NUMERO DEI PUNTI DI APPOGGIO** con rispettivo carico gravante.
2. **FREQUENZA ECCITANTE** determinata dal corpo rotante con r.p.m. più bassa.
3. **LUOGO D'INSTALLAZIONE:** se la macchina viene installata in una zona sismica, in copertura, se è soggetta alle forze del vento o in una zona con elevata presenza di nebbie saline o altri agenti aggressivi.
4. **TEMPERATURA D'IMPIEGO:** bisogna tenere in considerazione le temperature alle quali saranno soggetti i supporti antivibranti.

L'INSTALLAZIONE È CORRETTA QUANDO TUTTI I SUPPORTI INSTALLATI PRESENTANO LA STESSA FRECCIA ELASTICA.

Se le basi di appoggio dei diversi supporti antivibranti non sono tra loro a livello, è necessario compensare tale mancanza utilizzando appositi registri (MARTINETTI).

TO CHOOSE THE CORRECT ANTI-VIBRATION MOUNT, YOU MUST KNOW:

1. The **STATIC WEIGHT** of the machine and the **NUMBER OF SUPPORT POINTS** with their respective loads;
2. The **EXCITATION FREQUENCY** determined by the rotating body at the lowest r.p.m..
3. **INSTALLATION SITE:** if the machine is installed in a seismic area, on the roof, if it is subject to wind forces or in an area with high presence of saline mists or other aggressive agents.
4. **WORKING TEMPERATURE:** the temperatures to which the anti-vibration mounts will be subject must be taken into consideration.

THE INSTALLATION IS CORRECT WHEN ALL THE INSTALLED MOUNTS HAVE THE SAME ELASTIC DEFLECTION.

If the support bases of the different anti-vibration mounts are not among them at level, it is necessary to compensate for this lack using special registers (JACKS).

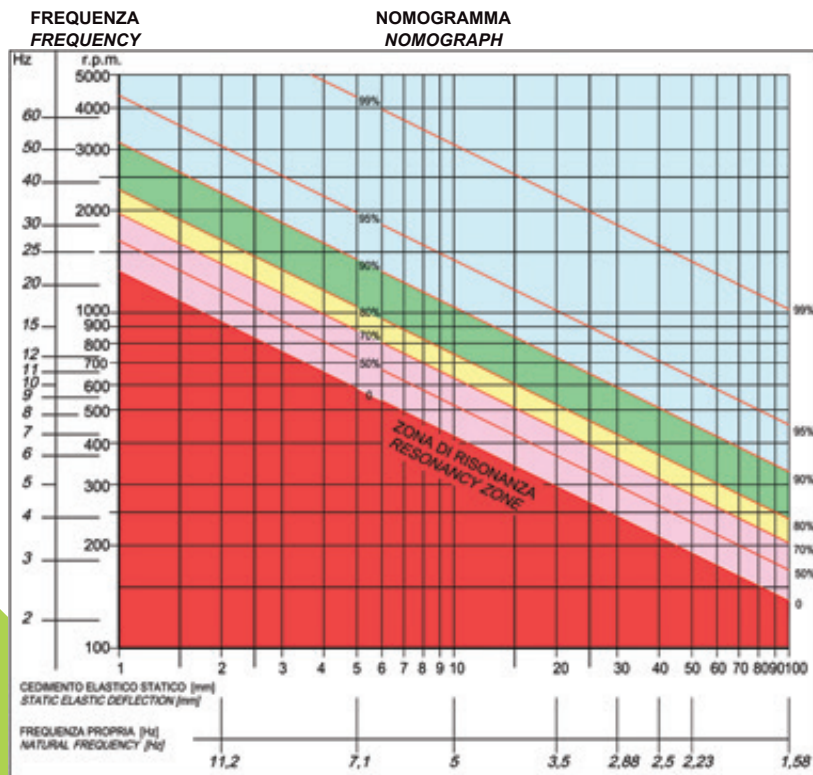

Il diagramma degli isolamenti, riassume graficamente, le relazioni intercorrenti tra la freccia elastica espressa in mm, il regime vibrante in r.p.m. o i cicli/mm e il grado di isolamento espresso in %.

The insulation diagram shows graphically the ratios between the elastic deflections in mm, the vibration speed in r.p.m. or cycles/mm and the degree of insulation as a %.

	ottima very good
	buona good
	discreta fair
	sufficiente sufficient
	zona di risonanza resonance zone

ESEMPIO DI SCELTA DI UN SUPPORTO ANTIVIBRANTE:

Si supponga di dover isolare un gruppo frigorifero di 6234 kg con una frequenza pari a 850 r.p.m. (14 Hz). L'unità ha 6 punti di appoggio, su ogni punto d'appoggio gravano 1039 kg (il carico è uniformemente distribuito). Per ottenere un isolamento del 90% ca. è necessario una deflessione di ca. 15 mm. Il carico diviso la deflessione determina la rigidità del supporto antivibrante "k" [kg/mm].

$$k = \frac{1039 \text{ kg (carico reale)}}{15 \text{ mm (deflessione)}} = 69.2 \text{ kg/mm}$$

Il Supporto Antivibrante mirato dovrà essere scelto nelle pagine a seguire, tra quelli che presentano rigidità "k" che meglio approssima il valore 69,2 [kg/mm]. Nella scelta del supporto antivibrante controllare che il carico massimo consigliato sia superiore al carico applicato.

Per la corretta installazione consultare l'apposita guida tecnica.

EXAMPLE OF CHOICE OF ANTI-VIBRATION MOUNT:

Suppose you need to isolate a 6234 kg refrigeration unit with one frequency equal to 850 r.p.m. (14 Hz). The unit has six resting points with 1039 kg resting on each point (the load is evenly distributed). To achieve about 90% insulation, a deflection of about 15 mm. is necessary. The load divided by the deflection determines the stiffness of the anti-vibration mount "k" [kg/mm].

$$k = \frac{1039 \text{ kg (real load)}}{15 \text{ mm (deflection)}} = 69.2 \text{ kg/mm}$$

The best anti-vibration mount will have to be chosen in the following pages, among those with a stiffness k that best approximates the value of 69.2 [kg/mm]. When choosing the anti-vibration mount, check that the maximum recommended load is higher than the load applied.

Please consult the technical guide for correct installation.

SERIE LaL
LaL SERIES

p. 3



SERIE LaL SPECIALE
LaL SPECIAL SERIES

p. 5

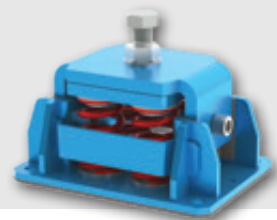

**MOLLE CON ALTA
DEFLESSIONE**
**SPRINGS WITH
HIGH
DEFLECTION**

SERIE LaLAH
LaLAH SERIES

p. 17



**MOLLE
RIDOTTE**
**REDUCED
SPRINGS**

SERIE LaLbZb - LaLbXb
LaLbZb - LaLbXb SERIES

p. 18



**LIVELLAZIONE
DELLA MACCHINA**
FACILITATA
**BUILT-IN LEVEL
ADJUSTMENT
DEVICE**

SERIE LaLS
LaLS SERIES

p. 19

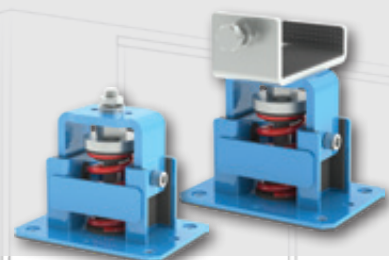

SERVIZIO IN KIT
KIT SERVICE

p. 29

Soleco engineering s.r.l. non si assume responsabilità nei casi dove si evidenzia l'errata installazione del supporto.

Soleco Engineering S.r.l. declines all responsibility in cases where the incorrect installation of the support is detected.

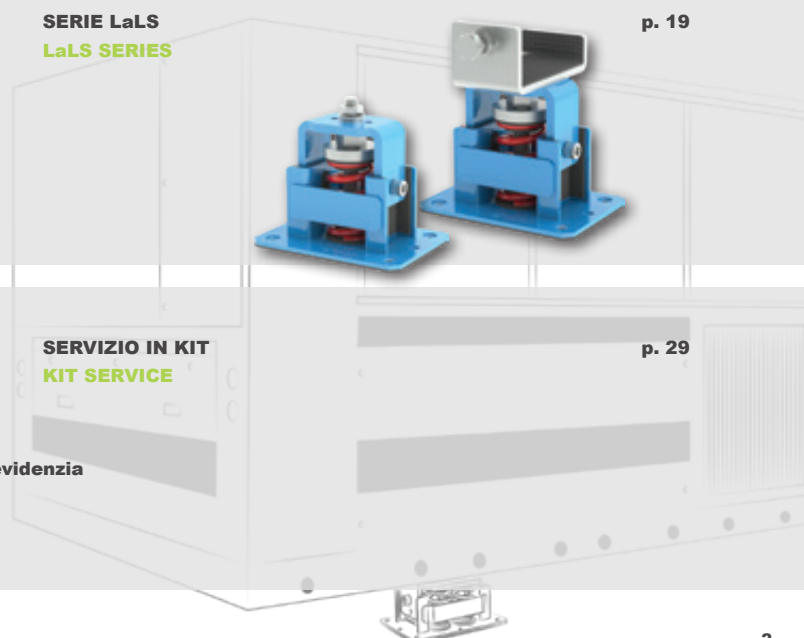

SERIE LaL LaL SERIES



CARATTERISTICHE COSTRUTTIVE

- **Costruzione solida e compatta in acciaio S235JR-UNI EN 10025 sabbiato, protetta da trattamento cataforetico, verniciata a polvere epossidica con viti in acciaio zincato.**
- **La struttura di contenimento è progettata per poter garantire un'elevata resistenza alle forze multidirezionali agenti sulla superficie della macchina sospesa in presenza di vento e/o movimenti tellurici.**
- **Molla/e in acciaio armonico UNI EN 10270-1 SH con superficie protetta da trattamento cataforetico.**
- **La gamma standard anti-sisma prevede dispositivi composti da un numero variabile di molle in grado di soddisfare un'estesa fascia di carico, da 17 kg a 10.000 kg per punto d'appoggio.**
- **Tramite esecuzioni speciali e strutture rinforzate è possibile raggiungere carichi di 15.000 kg per punto d'appoggio.**

MANUFACTURING CHARACTERISTICS

- **Solid and firm container structure made with S235JR-UNI EN 10025 steel sandblasted, protected by cathaphoretic treatment and epoxy powder coated.**
- **The external structure is designed to provide strong resistance to multidirectional forces generated by wind and/or telluric movements on the surface of the suspended machine.**
- **Spring/s in harmonic steel UNI EN 10270-1 SH with surface protected by cathaphoretic treatment.**
- **The standard anti-seismic line includes devices with one or more springs and the load capacity of this line goes from 17 kg to 10.000 kg for fixing point.**
- **Through special executions and reinforced structures it is possible to reach loads of 15.000 kg for fixing point.**

A RICHIESTA

- **Su richiesta vengono forniti cuscinetti smorzatori in elastomero (STRIPES), interposti tra le superfici di contatto che consentono di ridurre sensibilmente la trasmissione delle frequenze soniche.**

ON REQUEST

- **To reduce significantly the transmission of sonic frequencies we can provide elastomer bearings dampers (STRIPES) between the anti-vibration mount and the contact surface.**

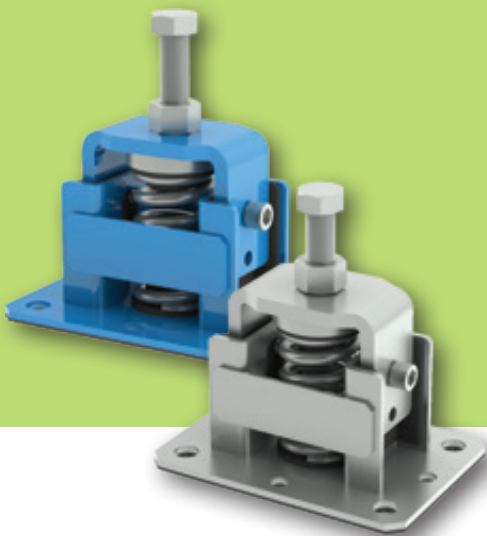
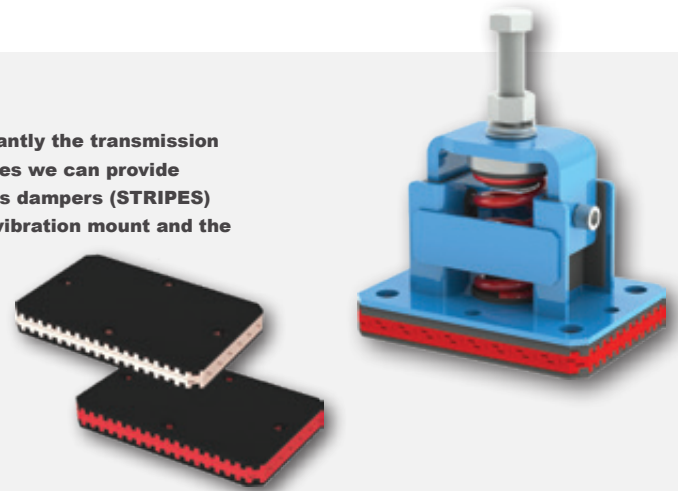

SOLUZIONI AD HOC

- **Su richiesta le parti metalliche possono essere realizzate in ACCIAIO INOX AISI 304 - 316 per isolare macchinari in estreme condizioni climatiche e in presenza di agenti atmosferici aggressivi o nebbie saline.**
- **L'ufficio Progettazione Soleco è a disposizione per assistere il Cliente in ogni sua richiesta e realizzare prodotti su misura.**

CUSTOMIZED SOLUTIONS

- **On request the container structure can be made in STAINLESS STEEL AISI 304 - 316 to insulate equipment's in extreme temperatures environments and in presence of aggressive atmospheric agent or salty fog.**
- **Soleco Technical Department can also provide assistance in the realization of customized solutions.**

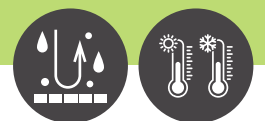



**CERTIFICAZIONI
SISMICHE
SEISMIC
CERTIFICATIONS**

I NOSTRI ANTISISMICI SONO CERTIFICATI

Gli antivibranti anti-sisma Soleco sono stati testati presso il Politecnico di Milano secondo standard ANSI/ASHRAE 171-2008 (Method of Testing Seismic Restraint devices for HVAC&R Equipment).

I livelli prestazionali e la metodologia di prova sono stati validati e certificati da **Lloyd's Register**.

OUR SEISMIC RESTRAINTS ARE CERTIFIED

Soleco anti-seismic line was tested following ANSI/ASHRAE Standard 171-2008 (Method of Testing Seismic Restraint devices for HVAC&R Equipment) at Polytechnic University of Milan.

Every test was supervised by a **Lloyd'S Register** surveyor to certify the compliance of the anti-seismic anti-vibration line.

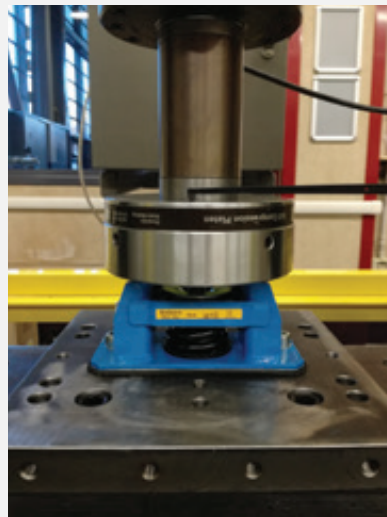

QUALIFICAZIONI SISMICHE E TEST FUNZIONALI

Per i nostri Clienti abbiamo ottenuto diverse certificazioni nel campo sismico.

Tutti i test sismici sono eseguiti da laboratori accreditati seguendo i requisiti di ICC-ES AC156 e ASCE 7-10 (che contiene le disposizioni antisismiche dell'International Building Code IBC).

Progettiamo e produciamo speciali basi sismiche per mantenere l'integrità strutturale delle unità dopo l'evento sismico e/o il test sismico eseguito su tavola a scossa triassiale.

SEISMIC QUALIFICATION AND FUNCTIONALITY TEST

For our Clients we have obtained several certifications in the seismic field.

All seismic tests are performed by accredited laboratories following the requirements of ICC-ES AC156 and ASCE 7-10 (which contains the seismic provisions of the International Building Code IBC).

We design and produce special seismic bases to maintain the structural integrity of the units after the seismic event and/or the seismic test performed on triaxial shake table.



**ANTIVIBRANTI
ANTISISMA SPECIALI
SPECIAL SEISMIC
DEVICES**

ANTIVIBRANTE ANTI-SISMA RINFORZATO

Per garantire ai nostri Clienti la partecipazione a progetti e appalti in cui si devono rispettare requisiti sismici particolari, possiamo fornire antisismici con struttura rinforzata.

REINFORCED ANTI-SEISMIC ANTI-VIBRATION MOUNT

We can supply reinforced anti-seismic mounts or customized solutions for projects and contracts with strict seismic requirements.



ANTIVIBRANTE ANTI-SISMA CON ANELLI IN ELASTOMERO

Le macchine con parti rotanti (ventilatori, pompe, generatori, ecc ...) sono influenzate da risonanze multiple durante l'avvio e l'arresto.

Questi fenomeni sono dovuti al fatto che la crescente frequenza del rotore tocca le diverse frequenze di risonanza del sistema (nei sistemi reali sono previste più di una frequenza di risonanza).

Per evitare questo problema inseriamo all'interno delle molle degli anelli in elastomero.

ANTI-SEISMIC ANTI-VIBRATION MOUNTS WITH ELASTOMERIC RINGS

Machines with rotating parts (fans, pumps, generators, ecc...) are affected by multiple resonances during start up and shut down.

These phenomena are due to the fact that the increasing frequency of the rotor touches the different resonance frequencies of the system (in real systems more than one resonance frequency are expected).

To avoid this problem we insert elastomer rings inside the springs.



Accelerazione verticale vs. tempo durante l'avvio della macchina
Vertical acceleration vs. time during machine startup



**IDEALE PER
MACCHINE CON
RISONANZE MULTIPLE
DURANTE L'AVVIO E L'ARRESTO.**

**SUITABLE FOR MACHINES
WITH MULTIPLE
RESONANCES DURING
START UP AND SHUT DOWN.**

**LIMITATORI
DI SPINTA SISMICA**
**SEISMIC
SNUBBERS**

LIMITATORI DI SPINTA SISMICA

Possiamo fornire limitatori di spinta elastomerici, spesso richiesti dai capitolati internazionali.

Questi limitatori vengono installati a distanza ravvicinata dalla macchina e agiscono come contenitori in caso di sisma o di altre forze impedendo così che la macchina si sposti o che si ribalti.

SEISMIC SNUBBERS

We can supply elastomeric thrust limiters, often required by international specifications.

These limiters are installed close to the machine and act as containers in the event of an earthquake or other forces thus preventing the machine from moving or overturning.

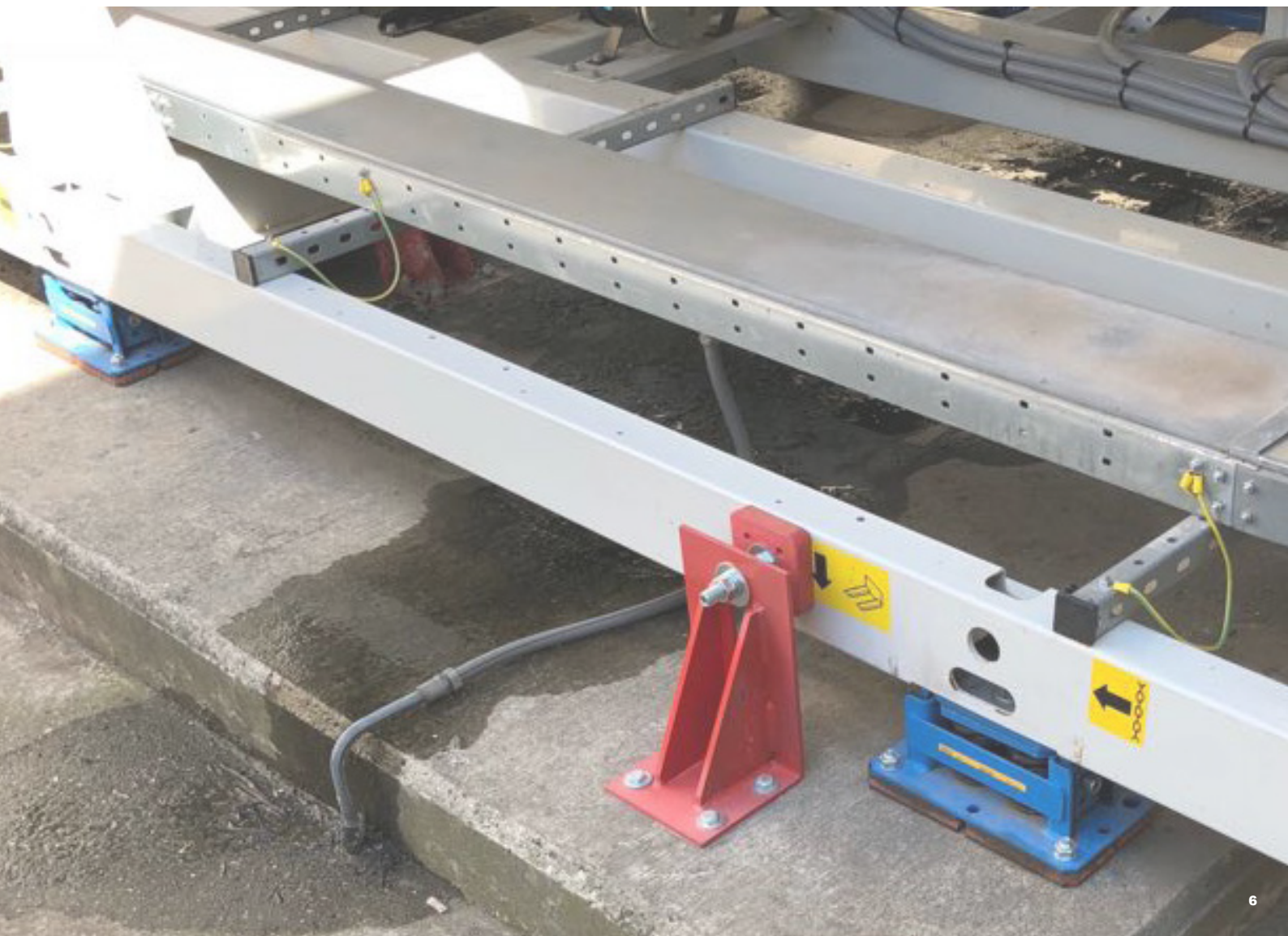
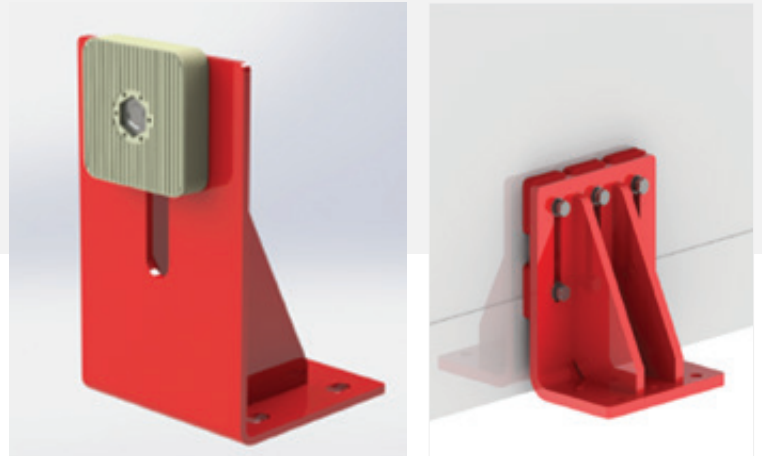

SERIE LaL
LaL SERIES

LaLrWr - LaLrVr

1

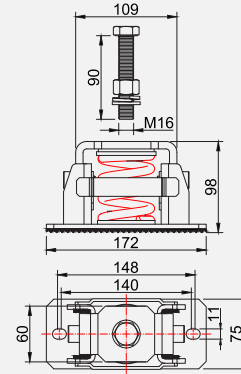

LaLW - LaLV

2

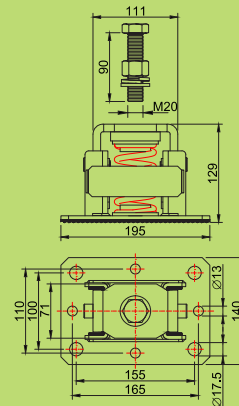

LaLWH - LaLVH

3

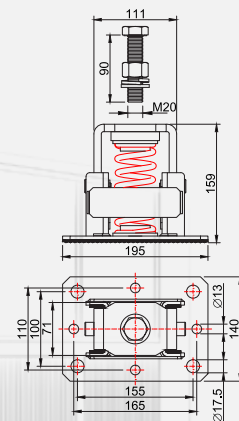
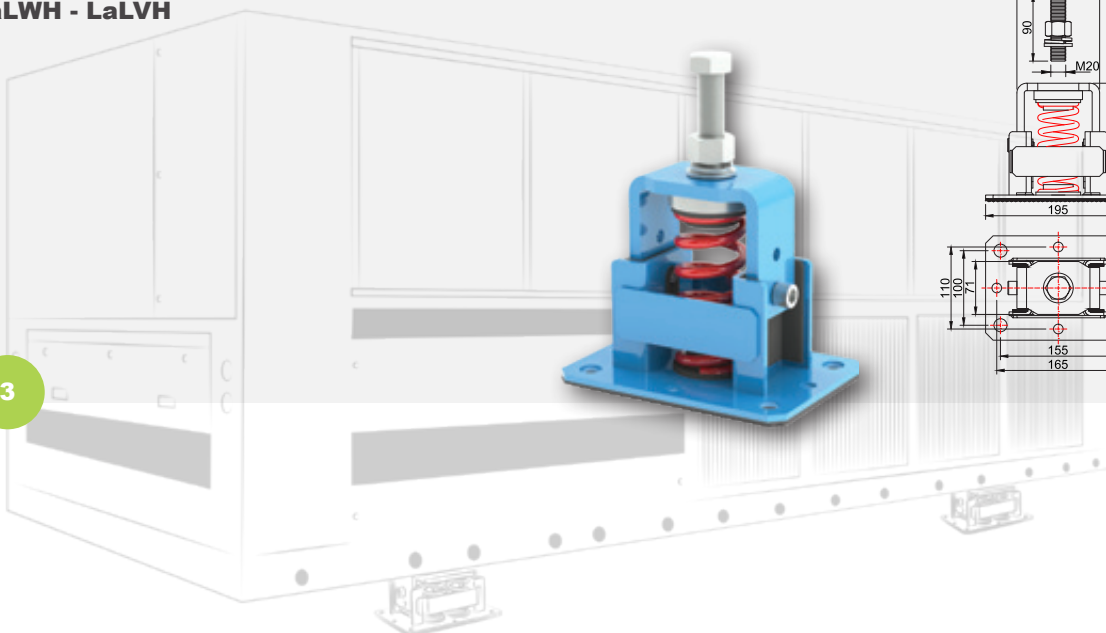

LaLrWr - LaLrVr

1

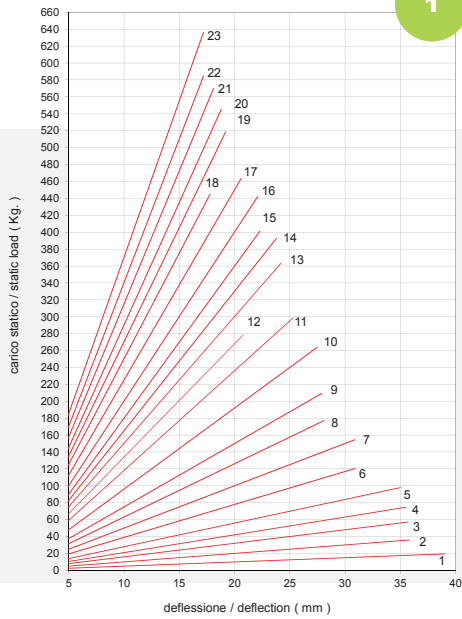

LaLW - LaLV

2

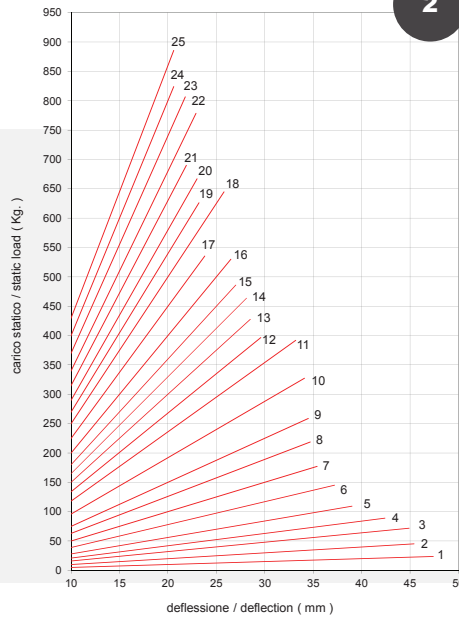

LaLWH - LaLVH

3

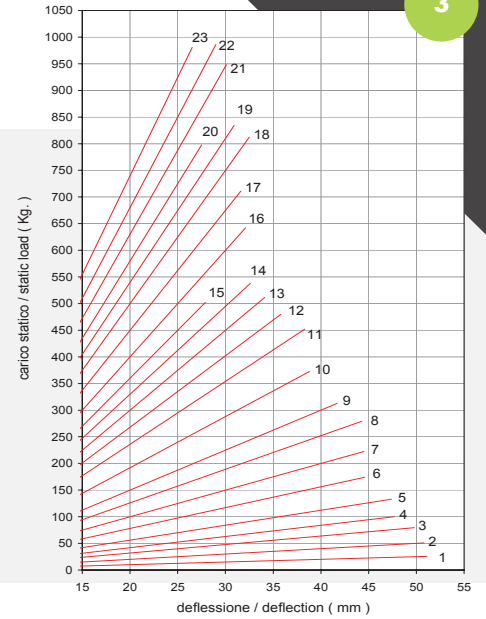

N.	MODEL	WEIGHT (kg)	k
1	LaLrWr 02	2.01	0.5
2	LaLrWr 04	2.03	1.0
3	LaLrWr 05	2.03	1.6
4	LaLrWr 06	2.12	2.1
5	LaLrWr 08	2.06	2.8
6	LaLrWr 09	2.10	3.9
7	LaLrWr 12	2.13	5.0
8	LaLrVr 14	2.16	6.3
9	LaLrVr 20	2.19	7.5
10	LaLrVr 22	2.20	9.6
11	LaLrVr 30	2.24	11.8
12	LaLrVr 300	2.25	13.4
13	LaLrVr 301	2.27	15.0
14	LaLrVr 305	2.29	16.5
15	LaLrVr 31	2.30	18.0
16	LaLrVr 33	2.26	20.0
17	LaLrVr 45	2.33	22.5
18	LaLrVr 47	2.38	25.0
19	LaLrVr 48	2.40	27.0
20	LaLrVr 50	2.48	29.0
21	LaLrVr 501	2.45	31.5
22	LaLrVr 510	2.44	34.0
23	LaLrVr 51	2.50	37.0

N.	MODEL	WEIGHT (kg)	k
1	LaLW 02	3.93	0.5
2	LaLW 04	3.96	1.0
3	LaLW 05	3.98	1.6
4	LaLW 06	4.01	2.1
5	LaLW 08	4.05	2.8
6	LaLW 09	4.09	3.9
7	LaLW 12	4.12	5.0
8	LaLV 14	4.17	6.3
9	LaLV 20	4.16	7.5
10	LaLV 22	4.27	9.6
11	LaLV 30	4.22	11.8
12	LaLV 300	4.28	13.4
13	LaLV 301	4.22	15.0
14	LaLV 305	4.34	16.5
15	LaLV 31	4.29	18.0
16	LaLV 33	4.37	20.0
17	LaLV 45	4.46	22.5
18	LaLV 47	4.48	25.0
19	LaLV 48	4.48	27.0
20	LaLV 50	4.41	29.0
21	LaLV 501	4.58	31.5
22	LaLV 510	4.66	34.0
23	LaLV 51	4.66	37.0
24	LaLV 53	4.46	40.0
25	LaLV 55	4.56	43.0

N.	MODEL	WEIGHT (kg)	k
1	LaLWH 02	4.02	0.5
2	LaLWH 04	4.08	1.0
3	LaLWH 05	4.17	1.6
4	LaLWH 06	4.17	2.1
5	LaLWH 08	4.23	2.8
6	LaLWH 09	4.19	3.9
7	LaLWH 12	4.23	5.0
8	LaLVH 14	4.28	6.3
9	LaLVH 20	4.35	7.5
10	LaLVH 22	4.42	9.6
11	LaLVH 30	4.39	11.8
12	LaLVH 300	4.38	13.4
13	LaLVH 301	4.68	15.0
14	LaLVH 305	4.61	16.5
15	LaLVH 31	4.78	18.0
16	LaLVH 33	4.68	20.0
17	LaLVH 45	4.68	22.5
18	LaLVH 47	4.73	25.0
19	LaLVH 48	4.83	27.0
20	LaLVH 50	4.90	29.0
21	LaLVH 501	4.79	31.5
22	LaLVH 510	4.89	34.0
23	LaLVH 51	5.00	37.0

CARATTERISTICHE
TECNICHE E
PERSONALIZZAZIONI
A PAGINA 3
MANUFACTURING
CHARACTERISTICS AND
CUSTOMIZATIONS
ON PAGE 3

SERIE LaL
LaL SERIES

LaLrWr2 - LaLrVr2

1

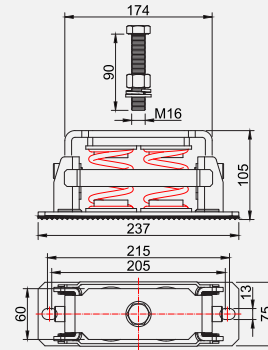
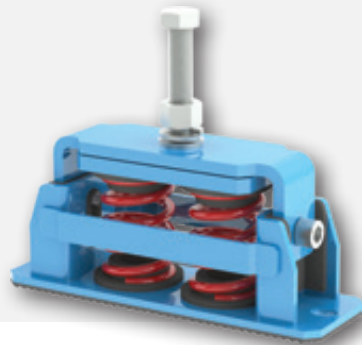

LaLW2 - LaLV2

2

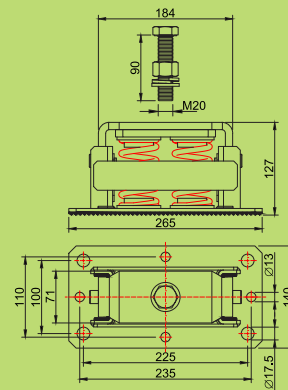

LaLWH2 - LaLVH2

3

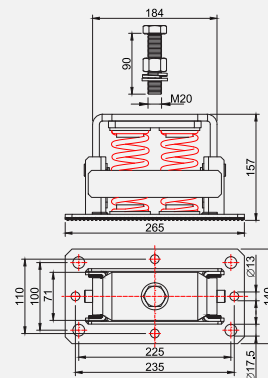
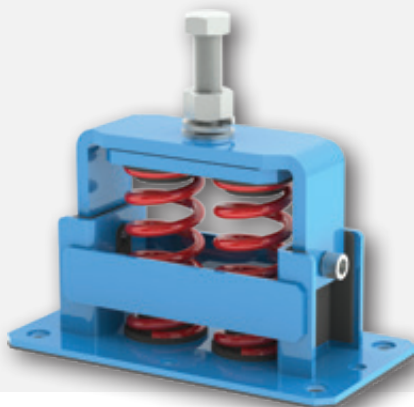

LaLrWr2 - LaLrVr2

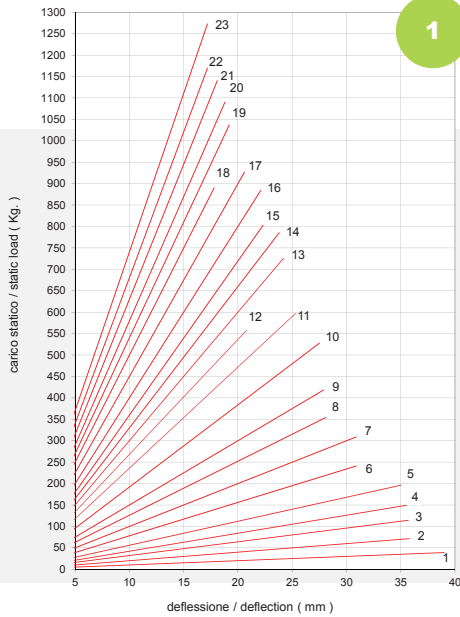

1

LaLW2 - LaLV2

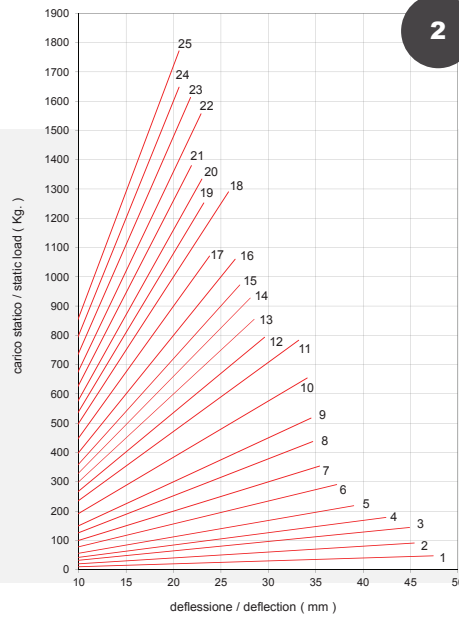

2

LaLWH2 - LaLVH2

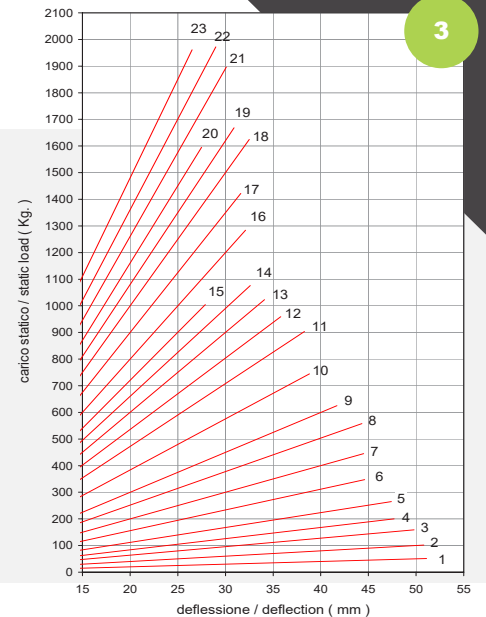

3

N.	MODEL	WEIGHT (kg)	k
1	LaLrWr 202	2.78	1.0
2	LaLrWr 204	2.81	2.0
3	LaLrWr 205	2.82	3.2
4	LaLrWr 206	2.99	4.2
5	LaLrWr 208	2.88	5.6
6	LaLrWr 209	2.95	7.8
7	LaLrWr 212	3.01	10.0
8	LaLrVr 214	3.08	12.6
9	LaLrVr 220	3.13	15.0
10	LaLrVr 222	3.16	19.2
11	LaLrVr 230	3.23	23.6
12	LaLrVr 2300	3.26	26.8
13	LaLrVr 2301	3.30	30.0
14	LaLrVr 2305	3.33	33.0
15	LaLrVr 231	3.36	36.0
16	LaLrVr 233	3.28	40.0
17	LaLrVr 245	3.42	45.0
18	LaLrVr 247	3.51	50.0
19	LaLrVr 248	3.56	54.0
20	LaLrVr 250	3.72	58.0
21	LaLrVr 2501	3.66	63.0
22	LaLrVr 2510	3.63	68.0
23	LaLrVr 251	3.75	74.0

N.	MODEL	WEIGHT (kg)	k
1	LaLW 202	5.33	1.0
2	LaLW 204	5.37	2.0
3	LaLW 205	5.42	3.2
4	LaLW 206	5.48	4.2
5	LaLW 208	5.56	5.6
6	LaLW 209	5.65	7.8
7	LaLW 212	5.69	10.0
8	LaLV 214	5.79	12.6
9	LaLV 220	5.79	15.0
10	LaLV 222	6.01	19.2
11	LaLV 230	5.89	23.6
12	LaLV 2300	6.01	26.8
13	LaLV 2301	5.91	30.0
14	LaLV 2305	6.14	33.0
15	LaLV 231	6.03	36.0
16	LaLV 233	6.20	40.0
17	LaLV 245	6.38	45.0
18	LaLV 247	6.41	50.0
19	LaLV 248	6.43	54.0
20	LaLV 250	6.28	58.0
21	LaLV 2501	6.61	63.0
22	LaLV 2510	6.77	68.0
23	LaLV 251	6.79	74.0
24	LaLV 253	6.38	80.0
25	LaLV 255	6.58	86.0

N.	MODEL	WEIGHT (kg)	k
1	LaLWH 202	5.49	1.0
2	LaLWH 204	5.62	2.0
3	LaLWH 205	5.79	3.2
4	LaLWH 206	5.81	4.2
5	LaLWH 208	5.91	5.6
6	LaLWH 209	5.83	7.8
7	LaLWH 212	5.92	10.0
8	LaLVH 214	6.02	12.6
9	LaLVH 220	6.17	15.0
10	LaLVH 222	6.31	19.2
11	LaLVH 230	6.23	23.6
12	LaLVH 2300	6.21	26.8
13	LaLVH 2301	6.83	30.0
14	LaLVH 2305	6.67	33.0
15	LaLVH 231	7.02	36.0
16	LaLVH 233	6.82	40.0
17	LaLVH 245	6.83	45.0
18	LaLVH 247	6.92	50.0
19	LaLVH 248	7.12	54.0
20	LaLVH 250	7.25	58.0
21	LaLVH 2501	7.04	63.0
22	LaLVH 2510	7.23	68.0
23	LaLVH 251	7.45	74.0

**CARATTERISTICHE
TECNICHE E
PERSONALIZZAZIONI
A PAGINA 3
MANUFACTURING
CHARACTERISTICS AND
CUSTOMIZATIONS
ON PAGE 3**

SERIE LaL
LaL SERIES

LaLrWr4 - LaLrVr4

1

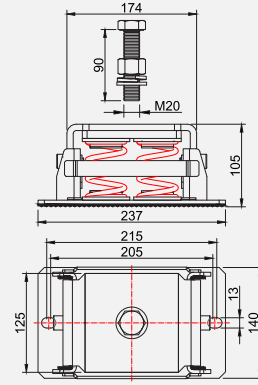

LaLW4 - LaLV4

2

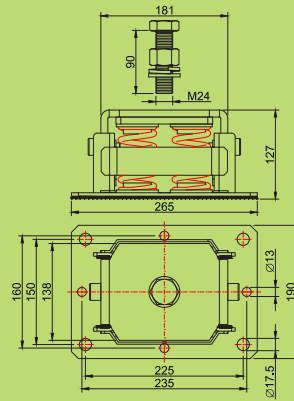

LaLWH4 - LaLVH4

3

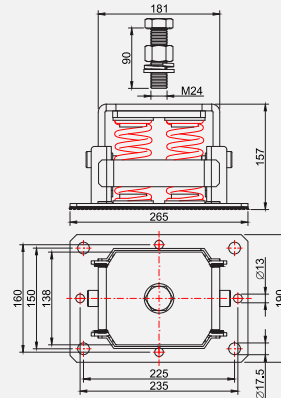
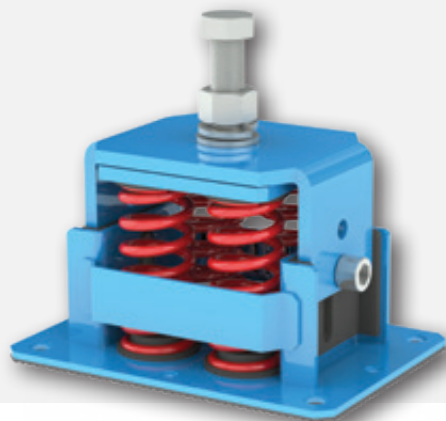

LaLrWr4 - LaLrVr4

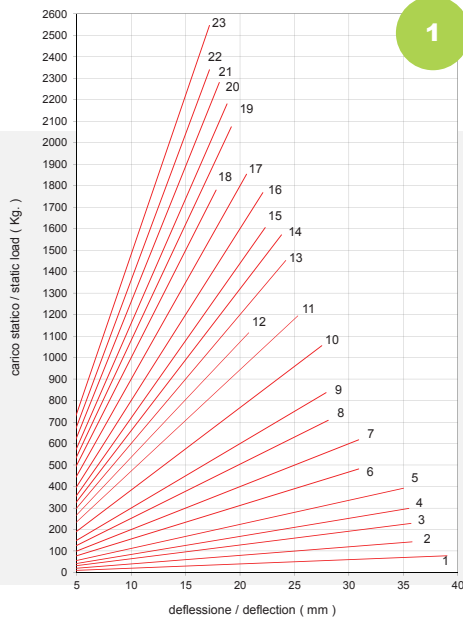

1

LaLW4 - LaLV4

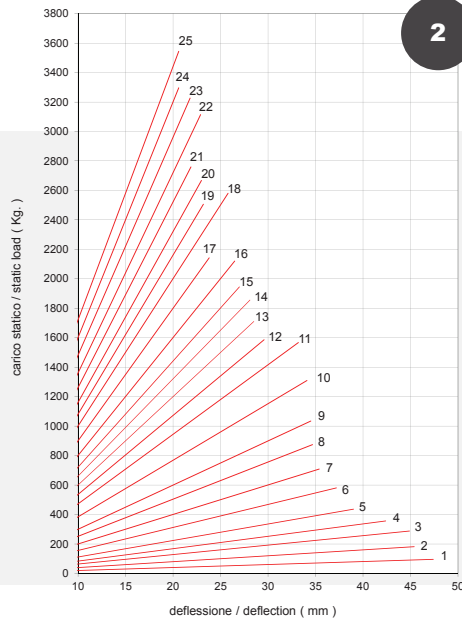

2

LaLWH4 - LaLVH4

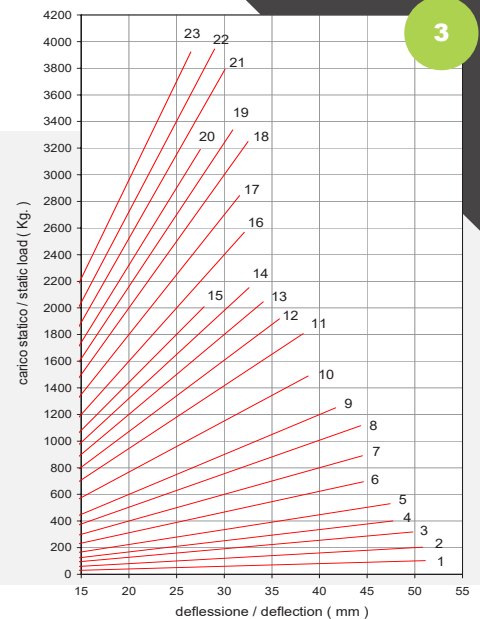

3

N.	MODEL	WEIGHT (kg)	k
1	LaLrWr 402	5.49	2.0
2	LaLrWr 404	5.55	4.0
3	LaLrWr 405	5.57	6.4
4	LaLrWr 406	5.91	8.4
5	LaLrWr 408	5.69	11.2
6	LaLrWr 409	5.83	15.6
7	LaLrWr 412	5.94	20.0
8	LaLrVr 414	6.08	25.2
9	LaLrVr 420	6.19	30.0
10	LaLrVr 422	6.25	38.4
11	LaLrVr 430	6.39	47.2
12	LaLrVr 4300	6.44	53.6
13	LaLrVr 4301	6.52	60.0
14	LaLrVr 4305	6.58	66.0
15	LaLrVr 431	6.64	72.0
16	LaLrVr 433	6.48	80.0
17	LaLrVr 445	6.77	90.0
18	LaLrVr 447	6.94	100.0
19	LaLrVr 448	7.04	108.0
20	LaLrVr 450	7.36	116.0
21	LaLrVr 4501	7.24	126.0
22	LaLrVr 4510	7.19	136.0
23	LaLrVr 451	7.42	148.0

N.	MODEL	WEIGHT (kg)	k
1	LaLW 402	8.24	2.0
2	LaLW 404	8.34	4.0
3	LaLW 405	8.43	6.4
4	LaLW 406	8.55	8.4
5	LaLW 408	8.72	11.2
6	LaLW 409	8.88	15.6
7	LaLW 412	8.98	20.0
8	LaLV 414	9.18	25.2
9	LaLV 420	9.16	30.0
10	LaLV 422	9.60	38.4
11	LaLV 430	9.37	47.2
12	LaLV 4300	9.60	53.6
13	LaLV 4301	9.37	60.0
14	LaLV 4305	9.61	66.0
15	LaLV 431	9.40	72.0
16	LaLV 433	9.87	80.0
17	LaLV 445	9.65	90.0
18	LaLV 447	9.99	100.0
19	LaLV 448	10.36	108.0
20	LaLV 450	10.42	116.0
21	LaLV 4501	10.44	126.0
22	LaLV 4510	10.15	136.0
23	LaLV 451	11.67	148.0
24	LaLV 453	12.06	160.0
25	LaLV 455	12.50	172.0

N.	MODEL	WEIGHT (kg)	k
1	LaLWH 402	8.57	2.0
2	LaLWH 404	8.84	4.0
3	LaLWH 405	9.17	6.4
4	LaLWH 406	9.20	8.4
5	LaLWH 408	9.41	11.2
6	LaLWH 409	9.25	15.6
7	LaLWH 412	9.43	20.0
8	LaLVH 414	9.34	25.2
9	LaLVH 420	9.92	30.0
10	LaLVH 422	10.20	38.4
11	LaLVH 430	10.08	47.2
12	LaLVH 4300	10.02	53.6
13	LaLVH 4301	11.24	60.0
14	LaLVH 4305	10.94	66.0
15	LaLVH 431	11.64	72.0
16	LaLVH 433	11.24	80.0
17	LaLVH 445	11.24	90.0
18	LaLVH 447	11.44	100.0
19	LaLVH 448	11.84	108.0
20	LaLVH 450	12.10	116.0
21	LaLVH 4501	11.67	126.0
22	LaLVH 4510	12.06	136.0
23	LaLVH 451	13.65	148.0

CARATTERISTICHE
TECNICHE E
PERSONALIZZAZIONI
A PAGINA 3
MANUFACTURING
CHARACTERISTICS AND
CUSTOMIZATIONS
ON PAGE 3

SERIE LaL
LaL SERIES

LaLW6 - LaLV6

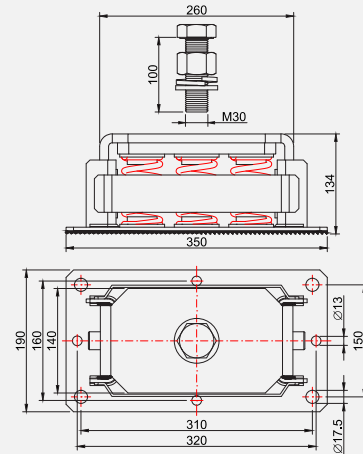

1

LaLWH6 - LaLVH6

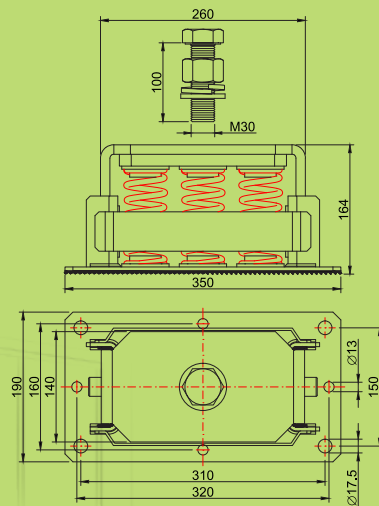

2

**CARATTERISTICHE
TECNICHE E
PERSONALIZZAZIONI
A PAGINA 3
MANUFACTURING
CHARACTERISTICS AND
CUSTOMIZATIONS
ON PAGE 3**

LaLW6 - LaLV6

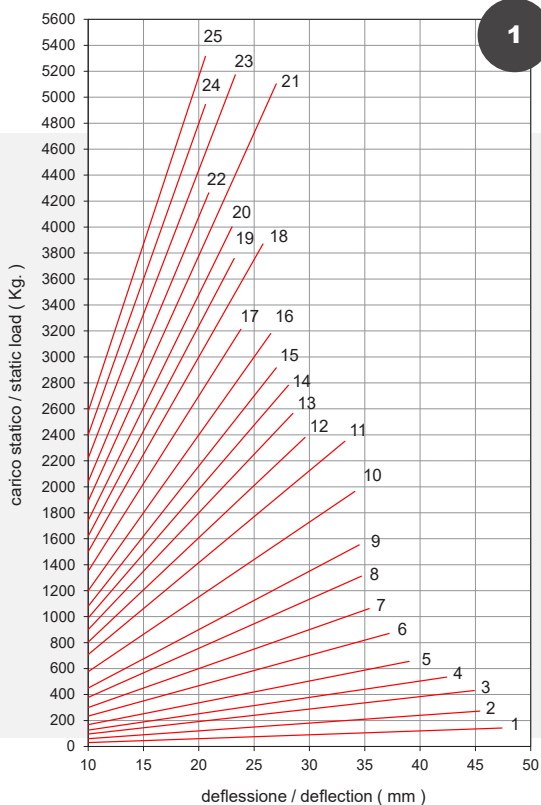

LaLWH6 - LaLVH6

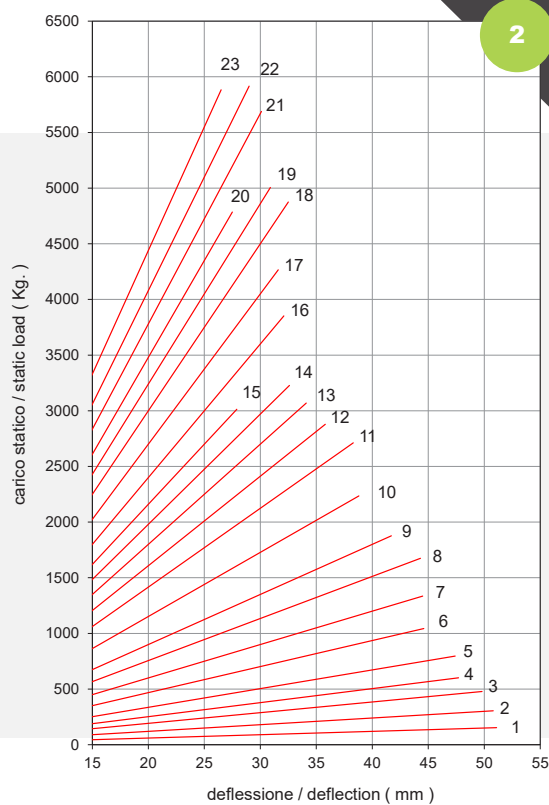

N.	MODEL	WEIGHT (kg)	k
1	LaLW 602	13.45	3.0
2	LaLW 604	13.60	6.0
3	LaLW 605	13.73	9.6
4	LaLW 606	13.91	12.6
5	LaLW 608	14.16	16.8
6	LaLW 609	14.41	23.4
7	LaLW 612	14.56	30.0
8	LaLV 614	14.86	37.8
9	LaLV 620	14.83	45.0
10	LaLV 622	15.49	57.6
11	LaLV 630	14.05	70.0
12	LaLV 6300	15.51	80.0
13	LaLV 6301	15.19	90.0
14	LaLV 6305	15.89	99.0
15	LaLV 631	15.57	108.0
16	LaLV 633	16.07	120.0
17	LaLV 645	16.62	135.0
18	LaLV 647	16.72	150.0
19	LaLV 648	16.75	162.0
20	LaLV 650	16.31	174.0
21	LaLV 6501	17.31	189.0
22	LaLV 6510	17.80	204.0
23	LaLV 651	17.83	222.0
24	LaLV 653	16.62	240.0
25	LaLV 655	17.21	258.0

N.	MODEL	WEIGHT (kg)	k
1	LaLWH 602	13.95	3.0
2	LaLWH 604	14.34	6.0
3	LaLWH 605	14.85	9.6
4	LaLWH 606	14.89	12.6
5	LaLWH 608	15.21	16.8
6	LaLWH 609	14.97	23.4
7	LaLWH 612	15.23	30.0
8	LaLVH 614	15.54	37.8
9	LaLVH 620	15.97	45.0
10	LaLVH 622	16.39	57.6
11	LaLVH 630	16.21	70.0
12	LaLVH 6300	16.12	80.0
13	LaLVH 6301	17.95	90.0
14	LaLVH 6305	17.50	99.0
15	LaLVH 631	18.54	108.0
16	LaLVH 633	17.94	120.0
17	LaLVH 645	17.95	135.0
18	LaLVH 647	18.24	150.0
19	LaLVH 648	18.84	162.0
20	LaLVH 650	19.24	174.0
21	LaLVH 6501	18.59	189.0
22	LaLVH 6510	19.18	204.0
23	LaLVH 651	19.84	222.0

SERIE LaL
LaL SERIES

LaLW9 - LaLV9

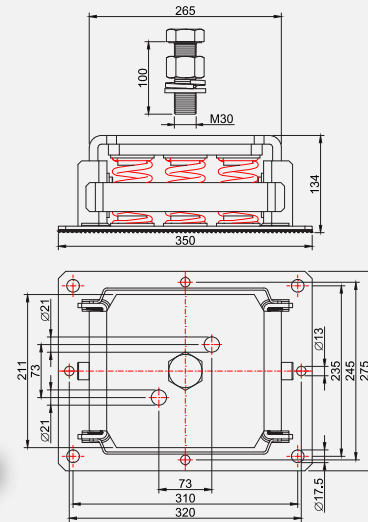
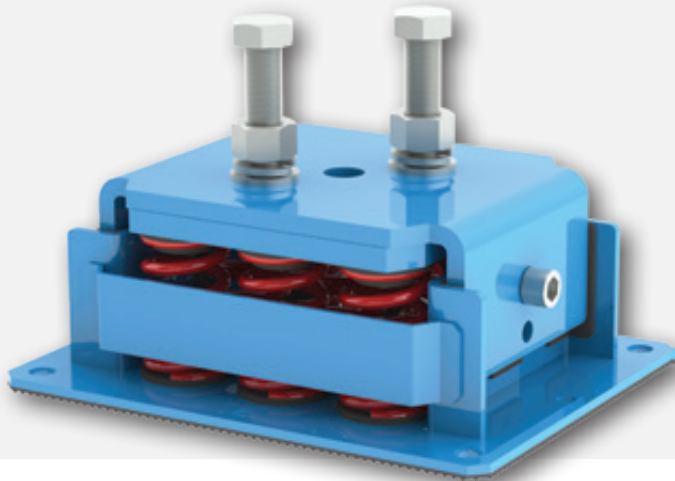

1

LaLWH9 - LaLVH9

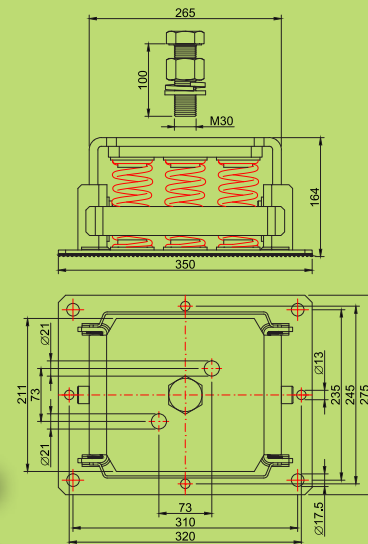

2



**CARATTERISTICHE
TECNICHE E
PERSONALIZZAZIONI
A PAGINA 3
MANUFACTURING
CHARACTERISTICS AND
CUSTOMIZATIONS
ON PAGE 3**

LaLW9 - LaLV9

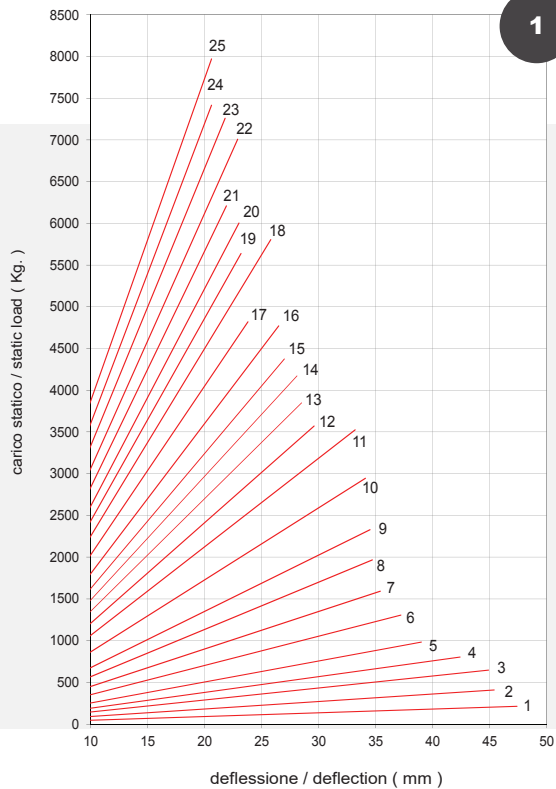

LaLWH9 - LaLVH9

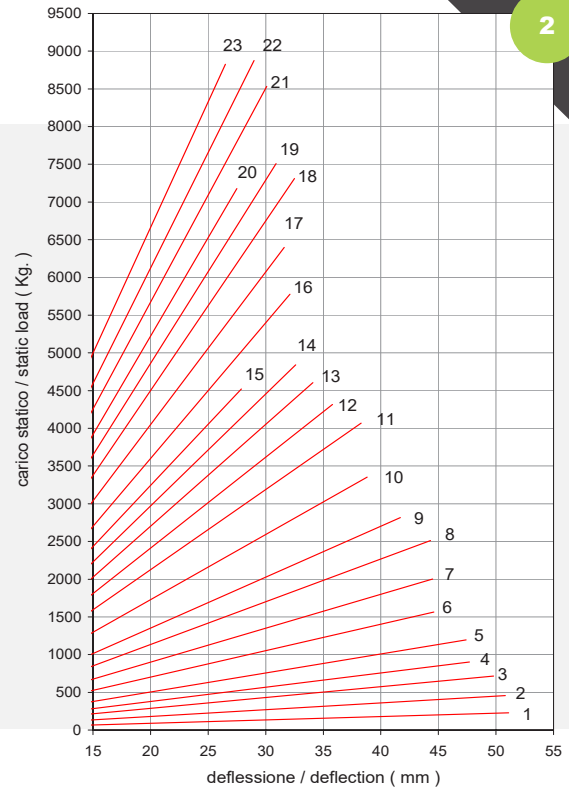

N.	MODEL	WEIGHT (kg)	k
1	LaLW 902	20.59	4.5
2	LaLW 904	20.80	9.0
3	LaLW 905	21.00	13.5
4	LaLW 906	21.27	18.9
5	LaLW 908	21.65	25.2
6	LaLW 909	22.03	35.1
7	LaLW 912	22.24	45.0
8	LaLV 914	22.69	56.7
9	LaLV 920	22.66	67.5
10	LaLV 922	23.65	86.4
11	LaLV 930	23.12	106.2
12	LaLV 9300	23.65	120.6
13	LaLV 9301	23.20	135.0
14	LaLV 9305	24.24	148.5
15	LaLV 931	23.75	162.0
16	LaLV 933	24.51	180.0
17	LaLV 945	25.34	202.5
18	LaLV 947	25.48	225.0
19	LaLV 948	25.54	243.0
20	LaLV 950	24.87	261.0
21	LaLV 9501	26.36	283.5
22	LaLV 9510	27.10	306.0
23	LaLV 951	27.16	333.0
24	LaLV 953	25.34	360.0
25	LaLV 955	26.22	387.0

N.	MODEL	WEIGHT (kg)	k
1	LaLWH 902	21.32	4.5
2	LaLWH 904	21.92	9.0
3	LaLWH 905	22.64	13.5
4	LaLWH 906	22.75	18.9
5	LaLWH 908	23.21	25.2
6	LaLWH 909	22.85	35.1
7	LaLWH 912	23.25	45.0
8	LaLVH 914	23.72	56.7
9	LaLVH 920	24.37	67.5
10	LaLVH 922	25.00	86.4
11	LaLVH 930	24.73	106.2
12	LaLVH 9300	24.58	120.6
13	LaLVH 9301	27.34	135.0
14	LaLVH 9305	26.65	148.5
15	LaLVH 931	28.22	162.0
16	LaLVH 933	27.32	180.0
17	LaLVH 945	27.34	202.5
18	LaLVH 947	27.77	225.0
19	LaLVH 948	28.67	243.0
20	LaLVH 950	29.26	261.0
21	LaLVH 9501	28.29	283.5
22	LaLVH 9510	29.17	306.0
23	LaLVH 951	30.16	333.0

SERIE LaLAH LaLAH SERIES

MOLLE AD ALTA DEFLESSIONE

- Antivibranti antisismici con molle speciali adatte ove viene richiesta una elevata deflessione.
- Solitamente utilizzati per isolare frequenze minime.

SPRINGS WITH HIGH DEFLECTION

- Anti-seismic anti-vibration mounts with special springs suitable where high deflection is required.
- Usually used to isolate minimum frequencies.

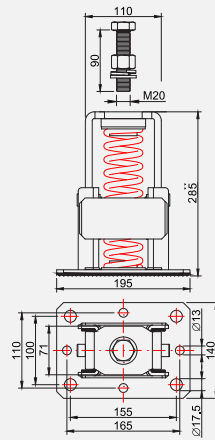

N.	MODEL	WEIGHT (kg)	k
1	LaLAH 00	6.29	1.5
2	LaLAH 01	6.37	2.0
3	LaLAH 02	6.42	2.7
4	LaLAH 03	6.82	3.7
5	LaLAH 04	6.97	4.6

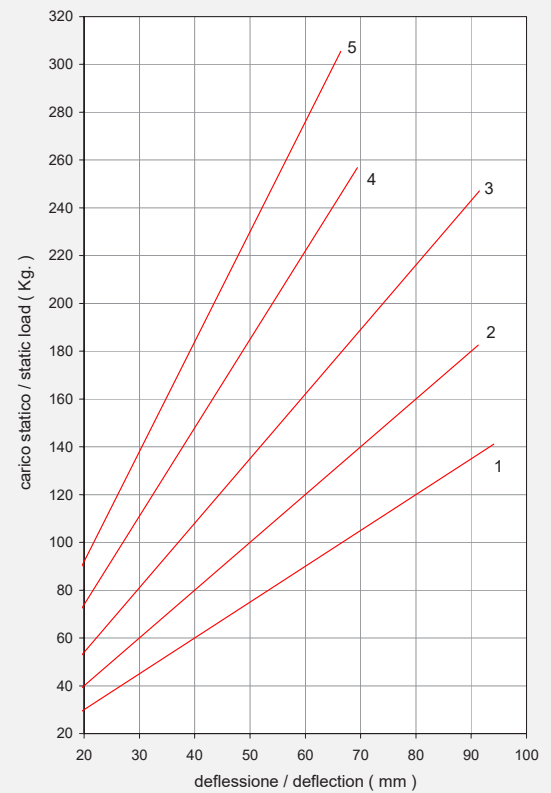

A RICHIESTA
Disponibile anche con più molle.

ON REQUEST
Available with more than 1 spring.

SERIE LaLb
LaLb SERIES

MOLLE RIDOTTE

- Idoneo per ventilatori o piccole unità dove sia richiesto un elevato grado di resistenza al sisma.

REDUCED SPRINGS

- Suitable for fans or small units where a degree of earthquake resistance is required.

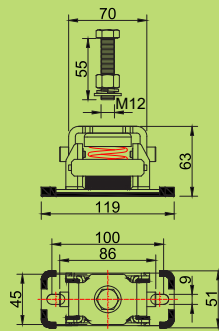

N.	MODEL	WEIGHT (kg)	k
1	LaLbZb 0	0.66	0.4
2	LaLbZb 1	0.66	0.7
3	LaLbZb 2	0.66	1.0
4	LaLbZb 3	0.67	1.7
5	LaLbZb 4	0.68	2.3
6	LaLbZb 5	0.68	3.0
7	LaLbZb 8	0.70	4.6
8	LaLbXb 10	0.69	6.0
9	LaLbXb 101	0.70	7.2
10	LaLbXb 11	0.73	9.0
11	LaLbXb 12	0.70	10.6
12	LaLbXb 13	0.71	13.0

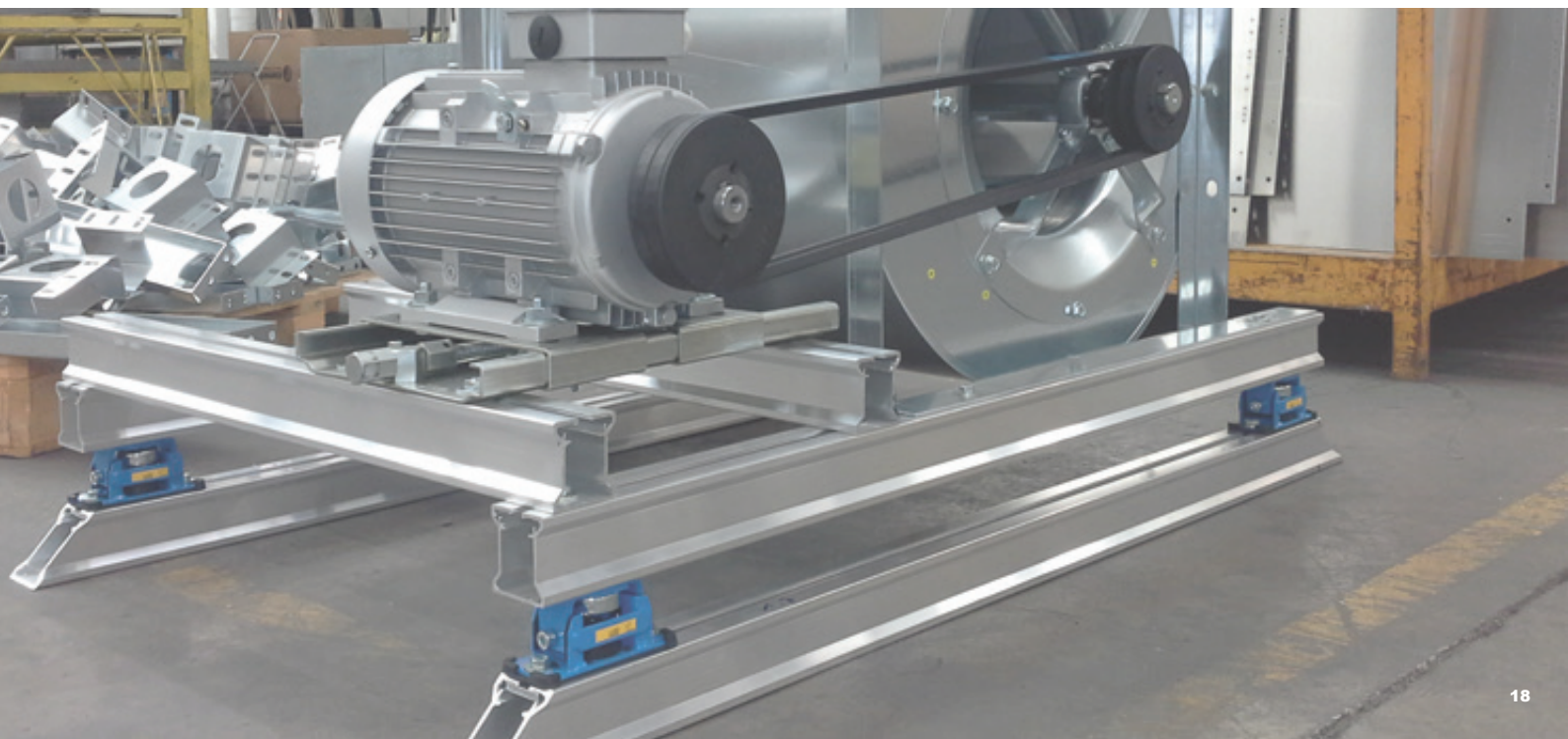
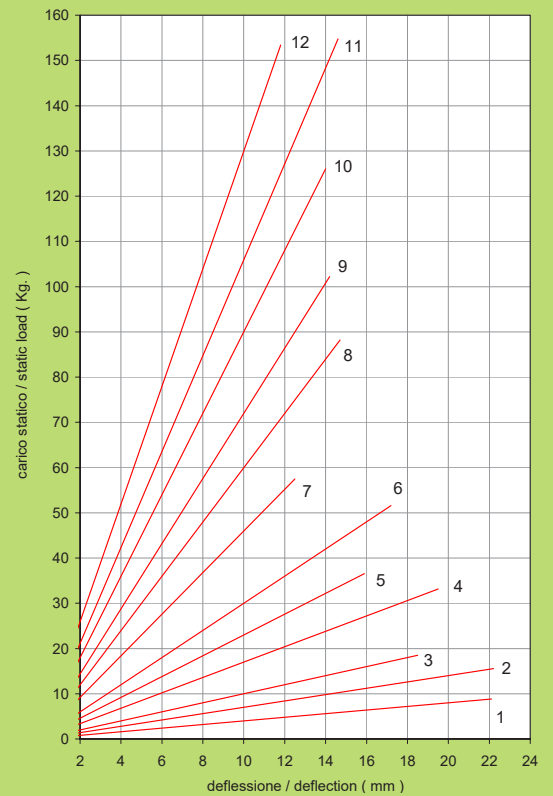

SERIE LaLS
LaLS SERIES

CARATTERISTICHE COSTRUTTIVE

- **Costruzione solida e compatta in acciaio S235JR-UNI EN 10025 sabbiato, protetta da trattamento cataforetico, verniciata a polvere epossidica con viti in acciaio zincato.**
- **La struttura di contenimento è progettata per poter garantire un'elevata resistenza alle forze multidirezionali agenti sulla superficie della macchina sospesa in presenza di vento e/o movimenti tellurici.**
- **Molla/e in acciaio armonico UNI EN 10270-1 SH con superficie protetta da trattamento cataforetico.**
- **La gamma standard anti-sisma prevede dispositivi composti da un numero variabile di molle in grado di soddisfare un'estesa fascia di carico, da 17 kg a 10.000 kg per punto d'appoggio.**
- **Tramite esecuzioni speciali e strutture rinforzate è possibile raggiungere carichi di 15.000 kg per punto d'appoggio.**

MANUFACTURING CHARACTERISTICS

- **Solid and firm container structure made with S235JR-UNI EN 10025 steel sandblasted, protected by cataphoretic treatment and epoxy powder coated.**
- **The external structure is designed to provide strong resistance to multidirectional forces generated by wind and/or telluric movements on the surface of the suspended machine.**
- **Spring/s in harmonic steel UNI EN 10270-1 SH with surface protected by cataphoretic treatment.**
- **The standard anti-seismic line includes devices with one or more springs and the load capacity of this line goes from 17 kg to 10.000 kg for fixing point.**
- **Through special executions and reinforced structures it is possible to reach loads of 15.000 kg for fixing point.**

SISTEMA DI REGISTRAZIONE INTERNA BREVETTATO

La serie di antivibranti antisismici LaLS ha un sistema di registrazione interna **BREVETTATO** che grazie alla presenza di codolo/i e dado/i consente all'installatore di registrare dall'interno il livello della macchina.

PATENTED BUILT-IN LEVEL ADJUSTMENT DEVICE

The LaLS series of anti-seismic anti-vibration mounts has a **PATENTED** internal adjustment system which, thanks to the presence of shank and nut, allows the installer to adjust the level of the machine from the inside.

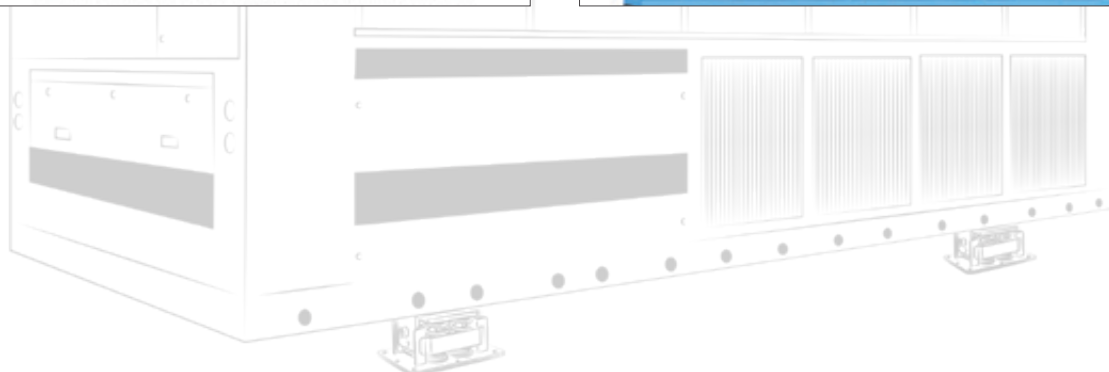
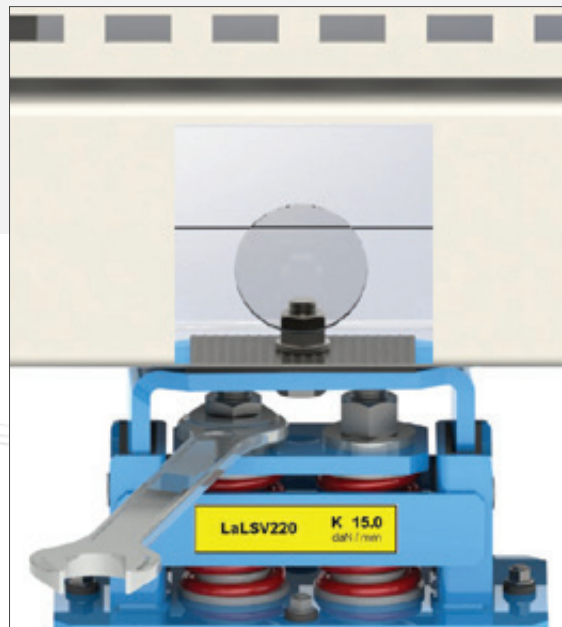
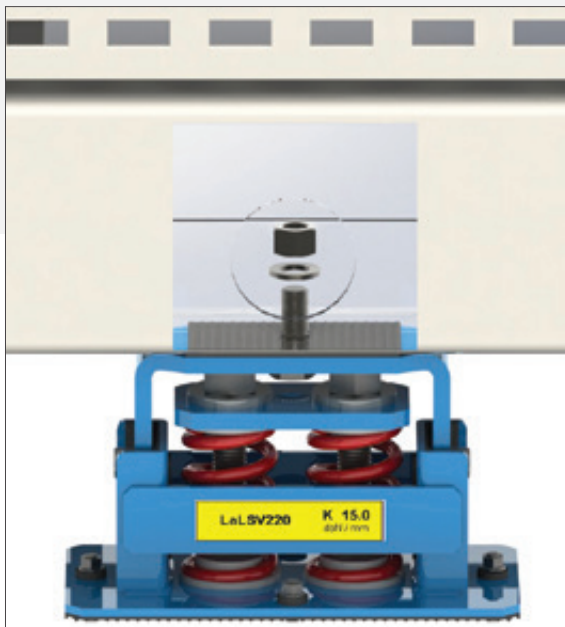

SERIE LaLS

LaLS SERIES

A RICHIESTA

- Su richiesta vengono forniti cuscinetti smorzatori in elastomero (STRIPES), interposti tra le superfici di contatto che consentono di ridurre sensibilmente la trasmissione delle frequenze sonore.

ON REQUEST

- To reduce significantly the transmission of sonic frequencies we can provide elastomer bearings dampers (STRIPES) between the anti-vibration mount and the contact surface.

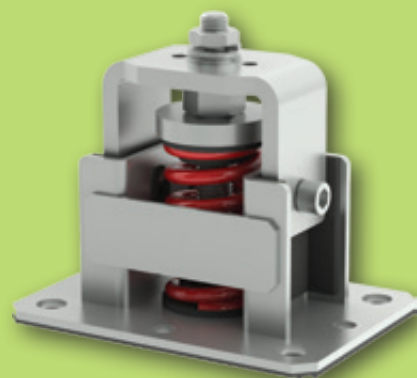
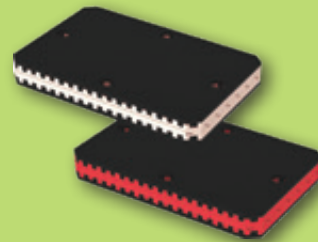
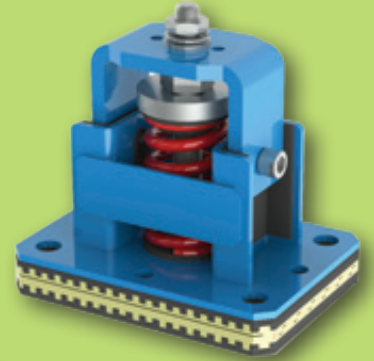

SOLUZIONI AD HOC

- Su richiesta le parti metalliche possono essere realizzate in ACCIAIO INOX AISI 304 - 316 per isolare macchinari in estreme condizioni climatiche e in presenza di agenti atmosferici aggressivi o nebbie saline.
- L'ufficio Progettazione Soleco è a disposizione per assistere il Cliente in ogni sua richiesta e realizzare prodotti su misura.

CUSTOMIZED SOLUTIONS

- On request the container structure can be made in STAINLESS STEEL AISI 304 - 316 to insulate equipment's in extreme temperatures environments and in presence of aggressive atmospheric agent or salty fog.
- Soleco Technical Department can also provide assistance in the realization of customized solutions.



SELLA PER FISSAGGIO

- A richiesta possiamo fornire una SELLA a C per il fissaggio.
- L'installazione eseguita con sella e morsetto consente di posizionare l'antivibrante lungo tutto il profilo della macchina così da poter trovare la posizione di fissaggio corretta.

BRACKETS FOR FIXING

- On request we can supply a C BRACKET for fixing.
- The installation performed with upper brackets and clamp allows the installer to place the anti-vibration mount along the entire machinery profile in order to find the right fixing positions.

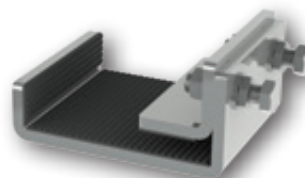
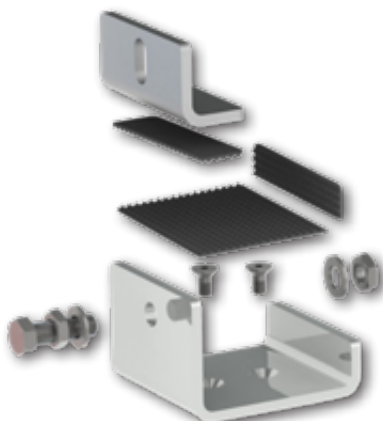

SERIE LaLS
LaLS SERIES

LaLrSWr - LaLrSVr

perno filettato M12
M12 threaded rod

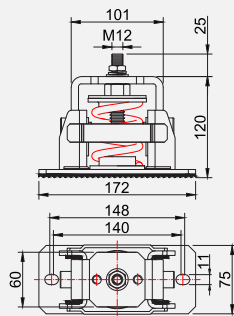
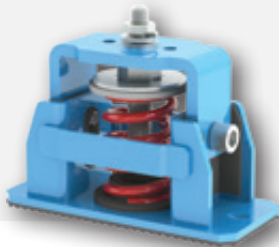

2 fori filettati M10
2 M10 threaded holes

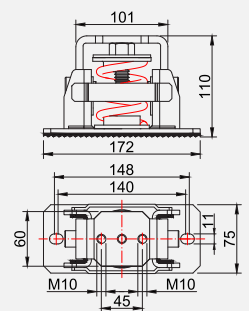
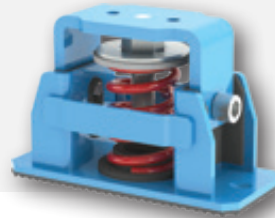

1

LaLSW - LaLSV

perno filettato M16
M16 threaded rod

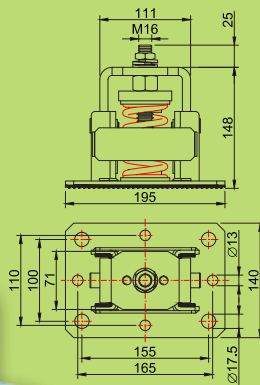
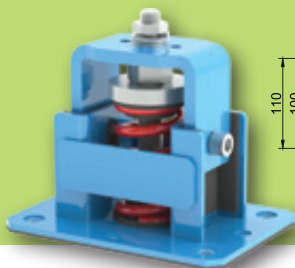

2 fori filettati M10
2 M10 threaded holes

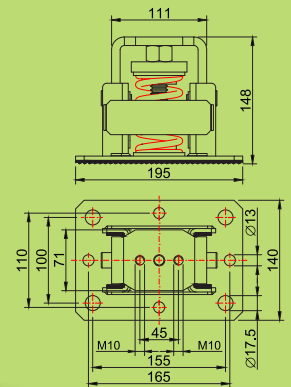

2

**CARATTERISTICHE
TECNICHE E
PERSONALIZZAZIONI
A PAGINA 19
MANUFACTURING
CHARACTERISTICS AND
CUSTOMIZATIONS
ON PAGE 19**

LaLrSWr - LaLrSVr

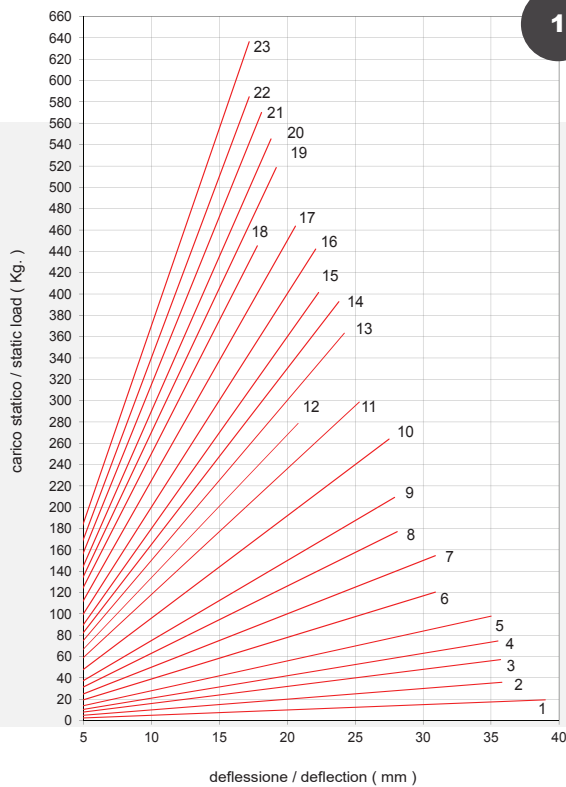

LaLSW - LaLSV

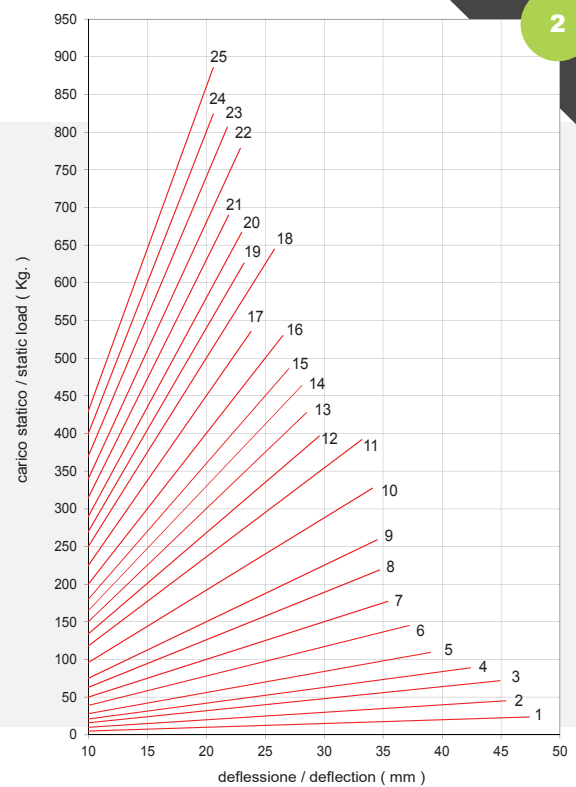

N.	MODEL	WEIGHT (kg)	k
1	LaLrSWr 02	2.09	0.5
2	LaLrSWr 04	2.10	1.0
3	LaLrSWr 05	2.11	1.6
4	LaLrSWr 06	2.19	2.1
5	LaLrSWr 08	2.14	2.8
6	LaLrSWr 09	2.17	3.9
7	LaLrSWr 12	2.20	5.0
8	LaLrSVr 14	2.23	6.3
9	LaLrSVr 20	2.26	7.5
10	LaLrSVr 22	2.28	9.6
11	LaLrSVr 30	2.31	11.8
12	LaLrSVr 300	2.32	13.4
13	LaLrSVr 301	2.34	15.0
14	LaLrSVr 305	2.36	16.5
15	LaLrSVr 31	2.37	18.0
16	LaLrSVr 33	2.33	20.0
17	LaLrSVr 45	2.41	22.5
18	LaLrSVr 47	2.45	25.0
19	LaLrSVr 48	2.47	27.0
20	LaLrSVr 50	2.55	29.0
21	LaLrSVr 501	2.52	31.5
22	LaLrSVr 510	2.51	34.0
23	LaLrSVr 51	2.57	37.0

N.	MODEL	WEIGHT (kg)	k
1	LaLSW 02	4.00	0.5
2	LaLSW 04	4.00	1.0
3	LaLrSW 05	4.10	1.6
4	LaLSW 06	4.10	2.1
5	LaLSW 08	4.10	2.8
6	LaLSW 09	4.20	3.9
7	LaLSW 12	4.20	5.0
8	LaLSV 14	4.30	6.3
9	LaLSV 20	4.30	7.5
10	LaLSV 22	4.40	9.6
11	LaLSV 30	4.30	11.8
12	LaLSV 300	4.40	13.4
13	LaLSV 301	4.30	15.0
14	LaLSV 305	4.40	16.5
15	LaLSV 31	4.40	18.0
16	LaLSV 33	4.50	20.0
17	LaLSV 45	4.60	22.5
18	LaLSV 47	4.60	25.0
19	LaLSV 48	4.60	27.0
20	LaLSV 50	4.50	29.0
21	LaLSV 501	4.70	31.5
22	LaLSV 510	4.70	34.0
23	LaLSV 51	4.80	37.0
24	LaLSV 53	4.60	40.0
25	LaLSV 55	4.60	43.0

SERIE LaLS
LaLS SERIES

**CARATTERISTICHE
TECNICHE E
PERSONALIZZAZIONI**
A PAGINA 19
**MANUFACTURING
CHARACTERISTICS AND
CUSTOMIZATIONS**
ON PAGE 19

LaLrSWr2 - LaLrSVr2

perno filettato M16
M16 threaded rod

2 fori filettati M10
2 M10 threaded holes

1

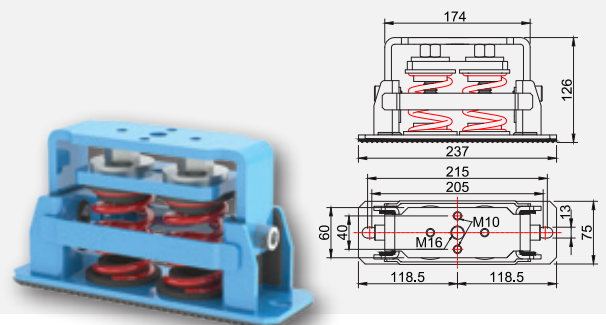
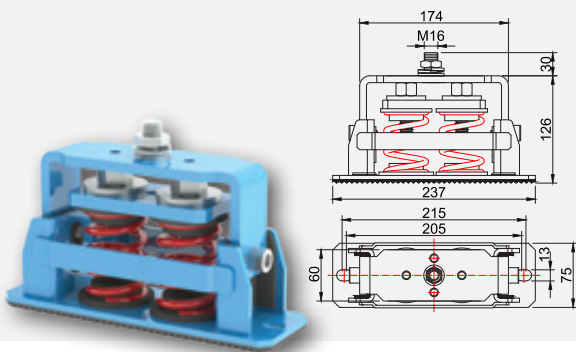

LaLSW2 - LaLSV2

perno filettato M16
M16 threaded rod

2 fori filettati M10
2 M10 threaded holes

2

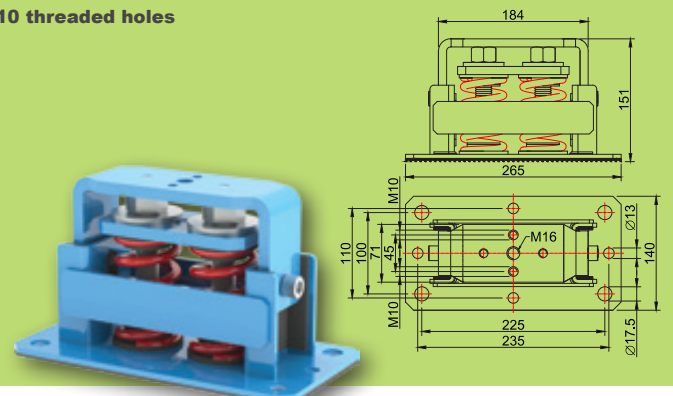
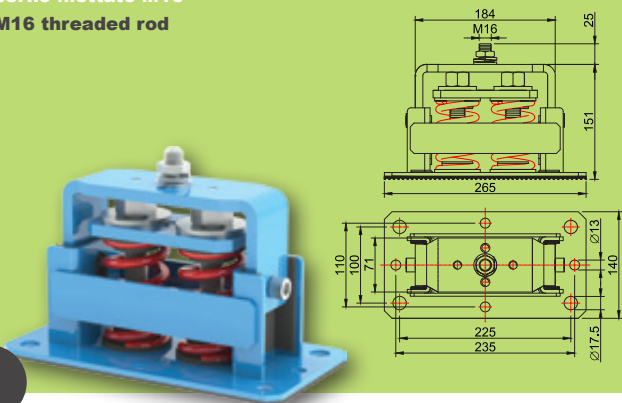

LaLrSWr2 - LaLrSVr2

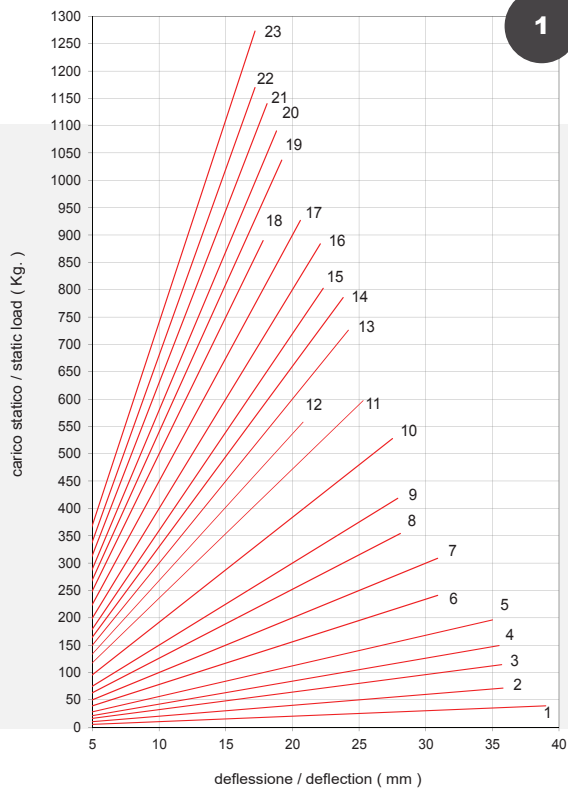

LaLSW2 - LaLSV2

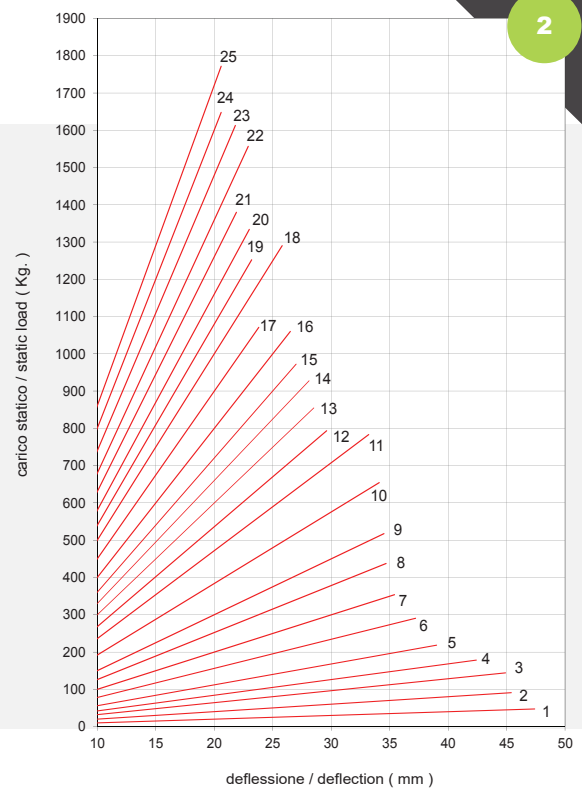

N.	MODEL	WEIGHT (kg)	k
1	LaLrSWr 202	3.34	1.0
2	LaLrSWr 204	3.36	2.0
3	LaLrSWr 205	3.38	3.2
4	LaLrSWr 206	3.54	4.2
5	LaLrSWr 208	3.44	5.6
6	LaLrSWr 209	3.50	7.8
7	LaLrSWr 212	3.56	10.0
8	LaLrSVr 214	3.63	12.6
9	LaLrSVr 220	3.68	15.0
10	LaLrSVr 222	3.72	19.2
11	LaLrSVr 230	3.78	23.6
12	LaLrSVr 2300	3.81	26.8
13	LaLrSVr 2301	3.85	30.0
14	LaLrSVr 2305	3.88	33.0
15	LaLrSVr 231	3.91	36.0
16	LaLrSVr 233	3.83	40.0
17	LaLrSVr 245	3.98	45.0
18	LaLrSVr 247	4.06	50.0
19	LaLrSVr 248	4.11	54.0
20	LaLrSVr 250	4.27	58.0
21	LaLrSVr 2501	4.21	63.0
22	LaLrSVr 2510	4.18	68.0
23	LaLrSVr 251	4.30	74.0

N.	MODEL	WEIGHT (kg)	k
1	LaLSW 202	5.40	1.0
2	LaLSW 204	5.50	2.0
3	LaLrSW 205	5.55	3.2
4	LaLSW 206	5.60	4.2
5	LaLSW 208	5.60	5.6
6	LaLSW 209	5.70	7.8
7	LaLSW 212	5.80	10.0
8	LaLSV 214	5.90	12.6
9	LaLSV 220	5.90	15.0
10	LaLSV 222	6.10	19.2
11	LaLSV 230	6.00	23.6
12	LaLSV 2300	6.10	26.8
13	LaLSV 2301	6.20	30.0
14	LaLSV 2305	6.20	33.0
15	LaLSV 231	6.20	36.0
16	LaLSV 233	6.30	40.0
17	LaLSV 245	6.40	45.0
18	LaLSV 247	6.40	50.0
19	LaLSV 248	6.60	54.0
20	LaLSV 250	6.60	58.0
21	LaLSV 2501	6.40	63.0
22	LaLSV 2510	6.90	68.0
23	LaLSV 251	6.80	74.0
24	LaLSV 253	6.76	80.0
25	LaLSV 255	6.70	86.0

SERIE LaLS
LaLS SERIES

LaLrSWr4 - LaLrSVr4

perno filettato M16
M16 threaded rod

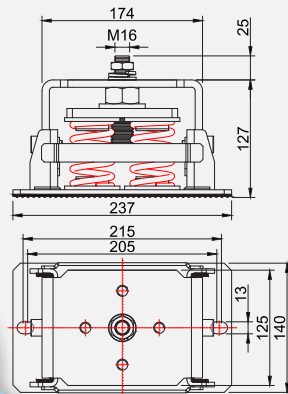

4 fori filettati M12
4 M12 threaded holes

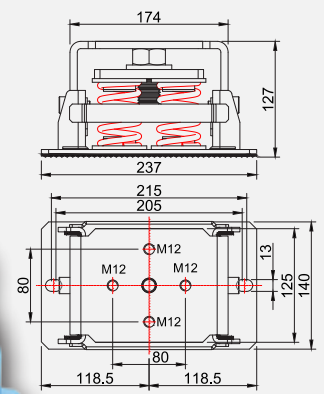

1

LaLSW4 - LaLSV4

perno filettato M16
M16 threaded rod

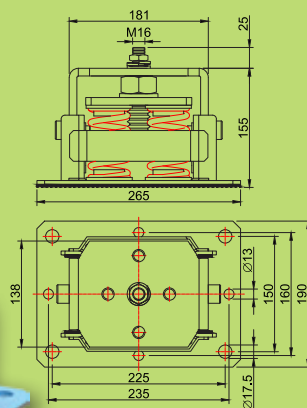

4 fori filettati M16
4 M16 threaded holes

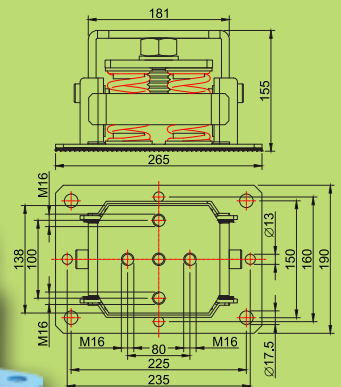

2

**CARATTERISTICHE
TECNICHE E
PERSONALIZZAZIONI
A PAGINA 19
MANUFACTURING
CHARACTERISTICS AND
CUSTOMIZATIONS
ON PAGE 19**

A RICHIESTA
Disponibile modello LaLSWH4 - LaLSVH4
per carichi superiori.

ON REQUEST
Available model LaLSWH4 - LaLSVH4
for higher loads.

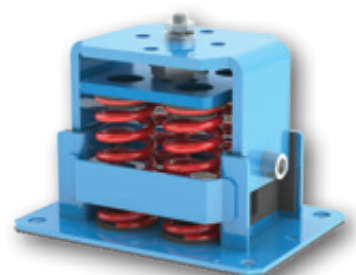

LaLrSWr4 - LaLrSVr4

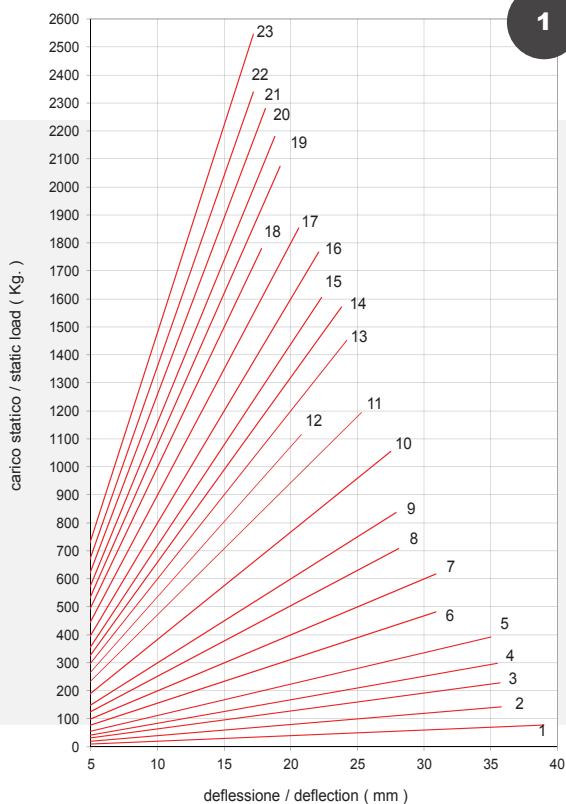

LaLSW4 - LaLSV4

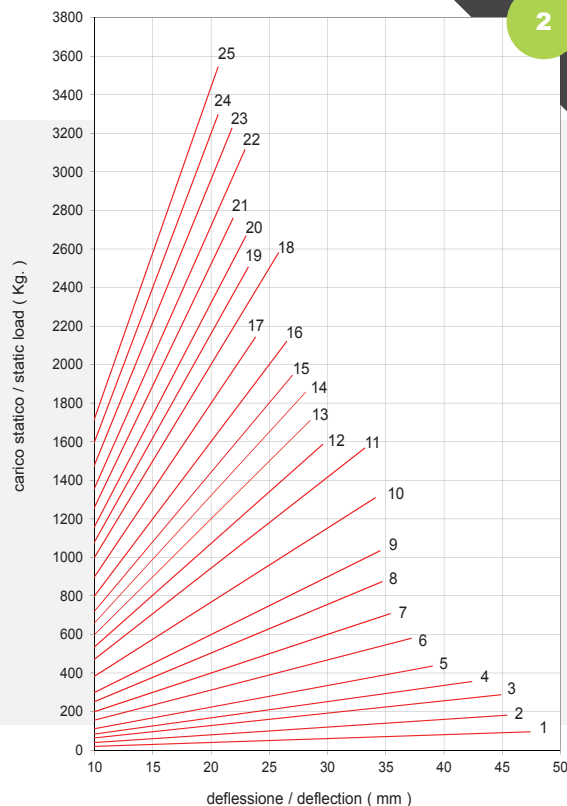

N.	MODEL	WEIGHT (kg)	k
1	LaLrSWr 402	7.33	2.0
2	LaLrSWr 404	7.39	4.0
3	LaLrSWr 405	7.41	6.4
4	LaLrSWr 406	7.75	8.4
5	LaLrSWr 408	7.53	11.2
6	LaLrSWr 409	7.67	15.6
7	LaLrSWr 412	7.78	20.0
8	LaLrSVr 414	7.92	25.2
9	LaLrSVr 420	8.03	30.0
10	LaLrSVr 422	8.09	38.4
11	LaLrSVr 430	8.23	47.2
12	LaLrSVr 4300	8.28	53.6
13	LaLrSVr 4301	8.36	60.0
14	LaLrSVr 4305	8.42	66.0
15	LaLrSVr 431	8.48	72.0
16	LaLrSVr 433	8.32	80.0
17	LaLrSVr 445	8.61	90.0
18	LaLrSVr 447	8.78	100.0
19	LaLrSVr 448	8.88	108.0
20	LaLrSVr 450	9.20	116.0
21	LaLrSVr 4501	9.08	126.0
22	LaLrSVr 4510	9.03	136.0
23	LaLrSVr 451	9.26	148.0

N.	MODEL	WEIGHT (kg)	k
1	LaLSW 402	11.00	2.0
2	LaLSW 404	11.10	4.0
3	LaLrSW 405	11.20	6.4
4	LaLSW 406	11.40	8.4
5	LaLSW 408	11.50	11.2
6	LaLSW 409	11.60	15.6
7	LaLSW 412	11.80	20.0
8	LaLSV 414	11.90	25.2
9	LaLSV 420	11.90	30.0
10	LaLSV 422	12.40	38.4
11	LaLSV 430	12.10	47.2
12	LaLSV 4300	12.40	53.6
13	LaLSV 4301	12.50	60.0
14	LaLSV 4305	12.60	66.0
15	LaLSV 431	12.70	72.0
16	LaLSV 433	12.80	80.0
17	LaLSV 445	13.00	90.0
18	LaLSV 447	13.00	100.0
19	LaLSV 448	13.30	108.0
20	LaLSV 450	13.40	116.0
21	LaLSV 4501	13.00	126.0
22	LaLSV 4510	14.00	136.0
23	LaLSV 451	13.40	148.0
24	LaLSV 453	13.70	160.0
25	LaLSV 455	13.60	172.0

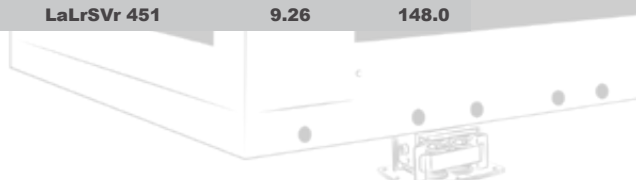

LaLSW6 - LaLSV6

perno filettato M20
M20 threaded rod

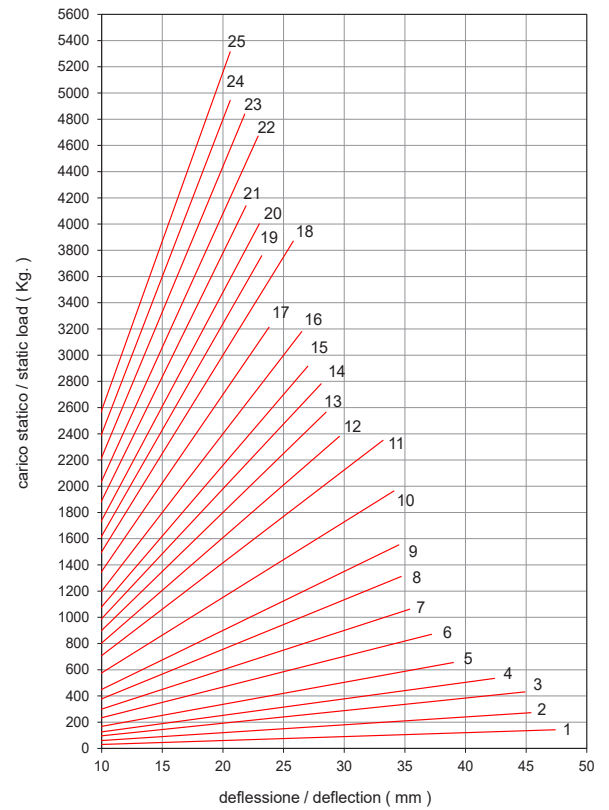
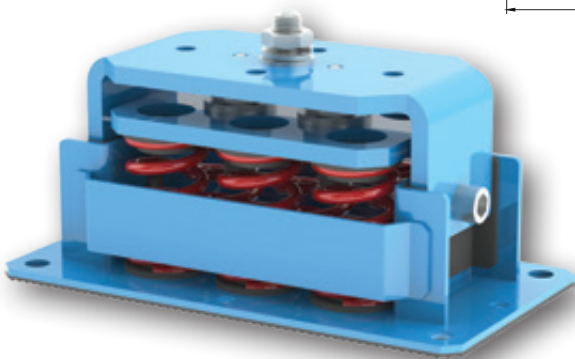
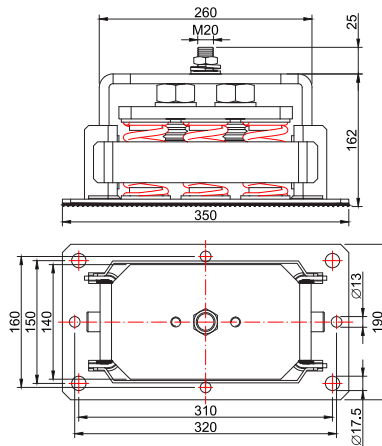

LaLSW6 - LaLSV6

4 fori filettati M16
4 M16 threaded holes

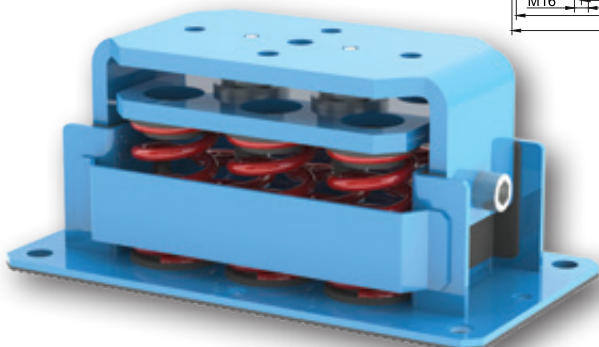
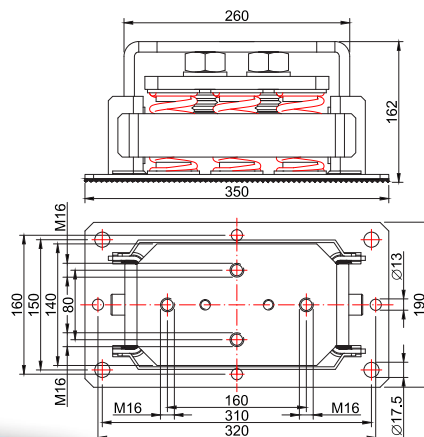

N.	MODEL	WEIGHT (kg)	k
1	LaLSW 602	12.90	3.0
2	LaLSW 604	13.20	6.0
3	LaLSW 605	13.30	9.6
4	LaLSW 606	13.70	12.8
5	LaLSW 608	14.00	16.8
6	LaLSW 609	14.30	23.4
7	LaLSW 612	14.60	30.0
8	LaLSV 614	15.00	37.8
9	LaLSV 620	15.00	45.0
10	LaLSV 622	16.00	57.6
11	LaLSV 630	15.50	70.0
12	LaLSV 6300	16.10	80.0
13	LaLSV 6301	16.30	90.0
14	LaLSV 6305	16.60	99.0
15	LaLSV 631	16.70	108.0
16	LaLSV 633	16.90	120.0
17	LaLSV 645	17.30	135.0
18	LaLSV 647	17.40	150.0
19	LaLSV 648	18.20	162.0
20	LaLSV 650	18.20	174.0
21	LaLSV 6501	17.30	189.0
22	LaLSV 6510	19.70	204.0
23	LaLSV 651	18.20	222.0
24	LaLSV 653	19.00	240.0
25	LaLSV 655	18.80	258.0

LaLSW9 - LaLSV9

perno filettato M20
M20 threaded rod

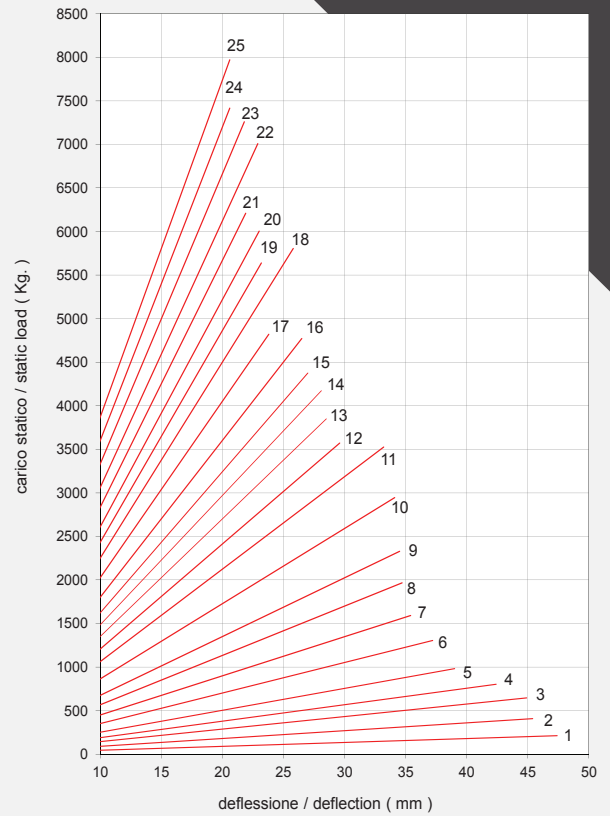
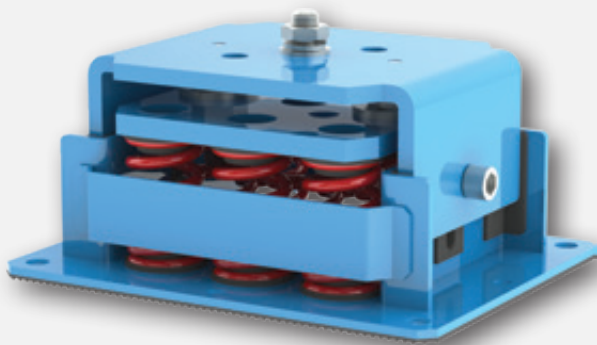
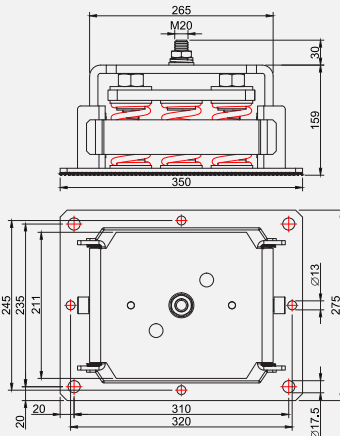

LaLSW9 - LaLSV9

3 fori filettati M20
3 M20 threaded holes

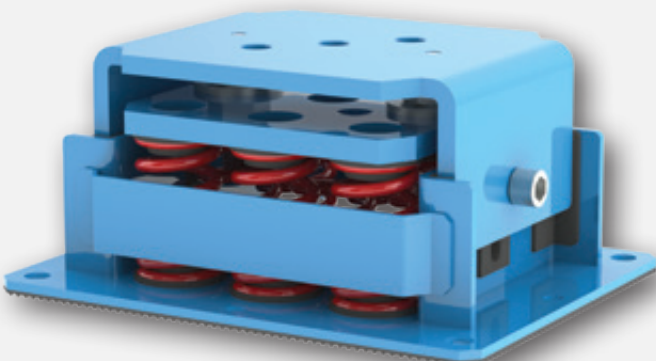
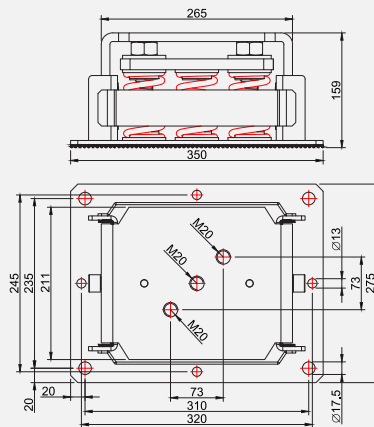

N.	MODEL	WEIGHT (kg)	k
1	LaLSW 902	20.90	4.5
2	LaLSW 904	21.20	9.0
3	LaLrSw 905	21.30	14.4
4	LaLSW 906	21.70	18.9
5	LaLSW 908	22.00	25.2
6	LaLSW 909	22.30	35.1
7	LaLSW 912	22.60	45.0
8	LaLSV 914	23.00	56.7
9	LaLSV 920	23.00	67.5
10	LaLSV 922	24.00	86.4
11	LaLSV 930	23.50	106.2
12	LaLSV 9300	24.10	120.6
13	LaLSV 9301	24.30	135.0
14	LaLSV 9305	24.60	148.5
15	LaLSV 931	24.70	162.0
16	LaLSV 933	24.90	180.0
17	LaLSV 945	25.30	202.5
18	LaLSV 947	25.40	225.0
19	LaLSV 948	26.20	243.0
20	LaLSV 950	26.20	261.0
21	LaLSV 9501	25.30	283.5
22	LaLSV 9510	27.70	306.0
23	LaLSV 951	26.20	333.0
24	LaLSV 953	27.00	360.0
25	LaLSV 955	26.80	387.0

A RICHIESTA
Disponibili modelli per carichi superiori.

ON REQUEST
Available models for higher loads.

SERVIZIO KIT KIT SERVICE

SERVIZIO KIT

Per i Clienti che hanno una produzione standardizzata, proponiamo un servizio di preselezione in modo da fornire un kit di antivibranti adatti a ogni modello di macchina.

Con questo servizio si dimezzano i tempi di fornitura e si facilitano le fasi di installazione.

Per maggiori informazioni su questo servizio vi invitiamo a contattare i nostri uffici.

KIT SERVICE

For Customers who have a production standardized, we offer a service of preselection in order to provide a kit of anti-vibration mounts suitable for each machine model.

With this service, delivery times are shorter and installation phases are facilitated.

For more information on this service, please contact our offices.

GUIDA ALL'INSTALLAZIONE

All'interno del kit viene inserita la documentazione tecnica riguardante i supporti antivibranti e le istruzioni per l'installazione degli antivibranti sotto la macchina.

Vengono inseriti i disegni delle macchine del Cliente, con i relativi codici e la spiegazione illustrata del posizionamento degli antivibranti.

Le guide possono essere personalizzate in diverse lingue e con il logo del Cliente.

INSTALLATION GUIDE

Technical documentation provided inside the kit explains the characteristics of the mounts and the instruction for the installation of anti-vibration mounts under the machine.

The drawings of the Customer's machines are inserted, with the relative codes and the illustrated explanation of the positioning of the mounts.

The guides can be customized in different languages and with the Customer's logo.

YOUR LOGO

ISTRUZIONI - GUIDE INSTRUCTIONS

INSTALLAZIONE DEI SUPPORTI ANTIVIBRANTI A MOLLA CON STRUTTURA ANTISISMICA serie LaLSV2... - LaLSW2...

INSTALLATION OF THE ANTI-VIBRATION SPRING MOUNTS WITH ANTISEISMIC STRUCTURE LaLSV2... - LaLSW2... series

Chiller WLAM742207C000 UT





cod. WPA_LASS_IT
rev. 04/2020

YOUR LOGO

PROCEDURA D'INSTALLAZIONE
ILLUSTRATED INSTALLATION PROCEDURE

STEP 1:

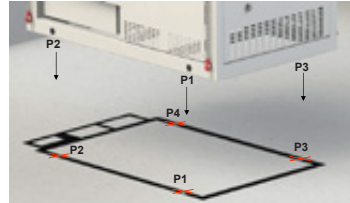
- Riportare sulla superficie d'appoggio l'impronta della macchina, evidenziando la posizione dei punti di appoggio della macchina.
- Make a sketch of the machine footprint and its supporting points onto the bearing structure (i.e. floor).



STEP 2:

- Utilizzare la maschera "base dell'antivibrante" consegnata con il kit, per ricavare sulla superficie d'appoggio la posizione dei supporti e i fori per l'ancoraggio.
- Use the template provided with the kit to mark fixing points of the anti-vibration mounts on the bearing structure.

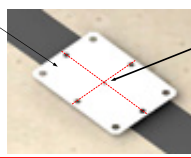

MASCHERA
ANTIVIBRANTE
MOUNT BASE
TEMPLATE

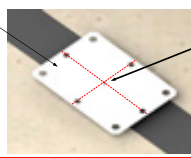

CENTRO
IMPRONTA
ANTIVIBRANTE
CENTRE OF
MOUNT
TEMPLATE

4

YOUR LOGO

PROCEDURA D'INSTALLAZIONE
ILLUSTRATED INSTALLATION PROCEDURE

STEP 3:

- Ancorare gli antivibranti a terra, utilizzando i fori precedentemente creati (E), con le viti appropriate.
- Al termine dell'operazione rimuovere le viti laterali di sicurezza TCEI M12 (F).
- Screw the anti-vibration mount to the bearing structure (i.e. floor) through the holes previously made (E).
- Remove the lateral TCEI M12 safety screws (F).





STEP 2:

- Appoggiare la macchina, scaricandone il peso simultaneamente su tutti gli antivibranti.
- Bloccare il dado (C) sui semi di filettaggio M16.
- Lower the machine so that all the anti-vibration mounts are loaded simultaneously.
- Tighten the nut (C) on the M16 anti-vibration mount locking rod.



**IDEALE PER
PRODUTTORI DI
MACCHINE IN SERIE**
**IDEAL FOR PRODUCERS OF
STANDARD MACHINES**

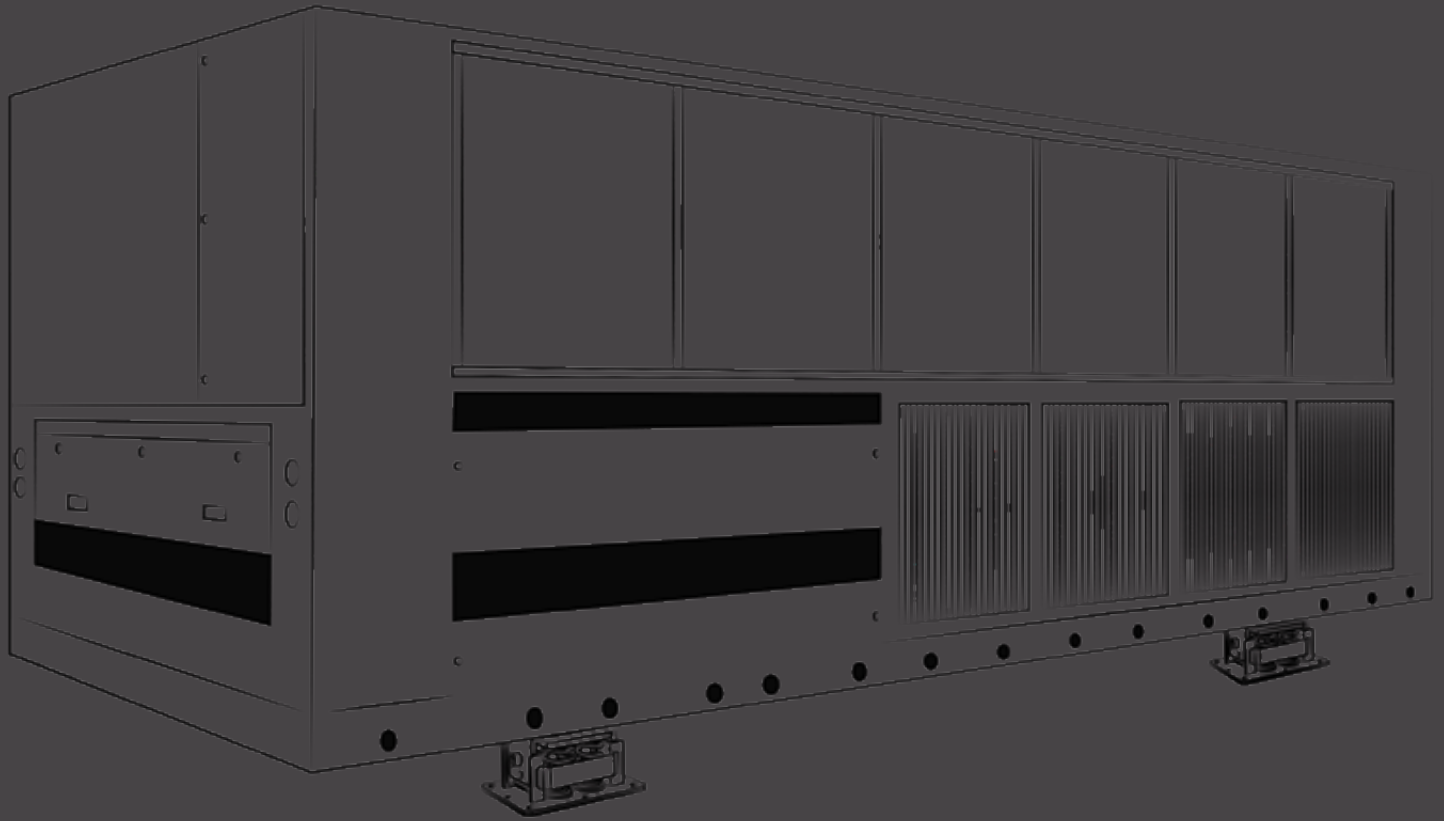



Soleco
engineering s.r.l.

www.solecosrl.com - soleco@solecosrl.com

via Masaccio 12, 20096 Pioltello (Mi) - Italy tel +39 02 92 44 311 - fax +39 02 73 96 50 50
cod.fisc. e p.IVA 01349290153 - reg. impr. MI 148283 M.9711244 - R.E.A. MI 835036