

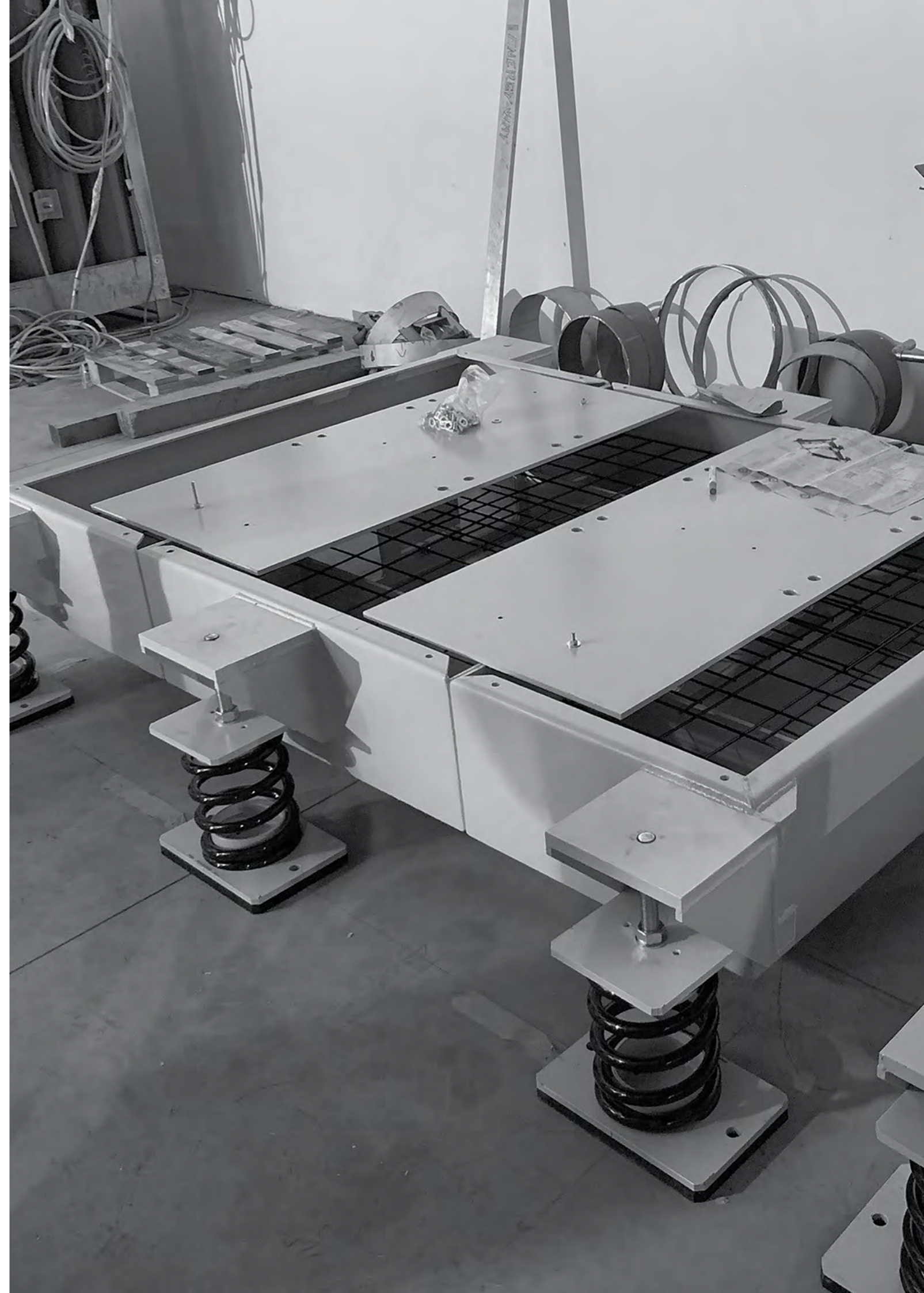

Soleco

ANTIVIBRANTI AD ALTO CARICO
APPLICAZIONE OIL & GAS
HIGH LOAD ANTI-VIBRATION MOUNT
APPLICATION OIL & GAS



L'AZIENDA

Siamo un'azienda italiana attiva da oltre 50 anni nel campo dell'isolamento delle vibrazioni, specializzata nell'analisi, nella progettazione e nella produzione di dispositivi e supporti antivibranti e antisismici.

Da sempre affrontiamo, con la stessa passione, sfide sempre più complesse che ci hanno portato ad acquisire prestigio internazionale, ponendoci come fornitore affidabile di aziende multinazionali in molteplici settori.

THE COMPANY

We are an Italian Company that has been operating for over 50 years in the vibration isolation sector, specialized in the analysis, design and manufacture of anti-vibration and seismic devices.

We have always been passionate about increasingly complex challenges that led us to gain international prestige as reliable supplier of multinational companies in several sectors.



SISTEMA DI GESTIONE CERTIFICATO

La certificazione UNI EN ISO 9001: 2015 garantisce un evoluto sistema aziendale di gestione della qualità, mirato al continuo miglioramento delle prestazioni e alla massima soddisfazione dei Clienti.

La fiducia confermata dai nostri Clienti è prova della qualità e affidabilità dei nostri prodotti.

CERTIFIED MANAGEMENT SYSTEM

The UNI EN ISO 9001: 2015 certification provides Soleco with a complete system that guarantees advanced quality management and focuses on the continuous performance improvement in order to ensure maximum Customer satisfaction.

The trust of our Customers is the proof of the quality and reliability of our products.

SUPPORTI ANTIVIBRANTI AD ALTO CARICO

Antivibranti a molla con struttura in acciaio UNI EN 10025 (S235JR/S355JR) ad alto carico, fino a 15 ton per punto di appoggio, con sistema di precompressione e regolazione in altezza. Possibilità di realizzare antivibranti a molla con deflessione oltre i 120 mm.

Le parti metalliche possono essere realizzate in acciaio INOX AISI 304 o 316 per resistere in condizioni climatiche estreme e in presenza di agenti atmosferici aggressivi e/o nebbie saline.

Verniciature speciali per ambienti da C1 a C5M e verniciatura NORSOK per applicazioni OFFSHORE. Aggiunta di lastre in PTFE e sistemi di scorrimento per applicazioni negli impianti.

L'ufficio R&D Soleco è a disposizione per assistere il Cliente in ogni sua richiesta e realizzare prodotti su misura.

HIGH LOAD ANTI-VIBRATION MOUNTS

High load spring anti-vibration mounts with UNI EN 10025 (S235JR/ S355JR) steel structure, up to 15 tons per support point, with prestressing and height adjustment system. Possibility of making spring antivibration mounts with deflection over 120 mm.

The metal parts can be made of AISI 304 or 316 stainless steel to withstand extreme climatic conditions and in the presence of aggressive atmospheric agents and/or saline mist.

Special paints for environments from C1 to C5M e NORSOK painting for OFFSHORE applications. Addition of PTFE sheets and sliding systems for plant applications.

Soleco R&D Office is available to support the Customer in any requests and create tailor-made products.

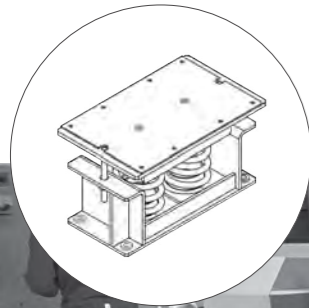
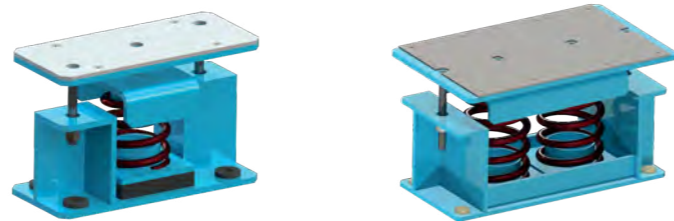

BASAMENTI INERZIALI

Basamenti inerziali con struttura in acciaio UNI EN 10025 (S235JR/S355JR) e antivibranti a molla, ad alta deflessione, regolabili in altezza per compensare distribuzioni non uniformi del carico.

I basamenti vengono dimensionati e verificati strutturalmente dal nostro Ufficio Tecnico.

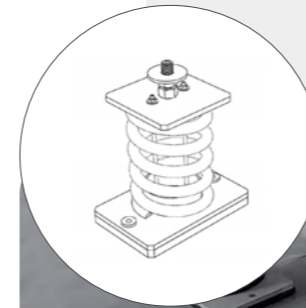

INERTIAL BASES

Inertial bases with UNI EN 10025 steel structure (S235JR/S355JR) and spring anti-vibration mounts, with high deflection, adjustable in height to compensate for non-uniform load distributions.

The bases are sized and structurally checked by our Technical Department.

SOSPENSIONI ANTIVIBRANTI PER TUBAZIONI AD ALTO CARICO

Sospensioni antivibranti a molla con struttura di contenimento in acciaio UNI EN 10025 (S235JR/S355JR) per l'isolamento di tubazioni ad alto carico fino a 3 ton per punto, le sospensioni sono fornite con sistema di precompressione ad alta sicurezza.

Guarnizioni elastiche per l'isolamento delle alte frequenze.

SPRING HANGERS FOR HIGH LOAD PIPES

Spring anti-vibration suspensions with containment structure in UNI EN 10025 steel (S235JR/S355JR) for the insulation of high-load pipes up to 3 tons per point, the suspensions are supplied with a high-security prestressing system.

Elastic gaskets for high frequency insulation.

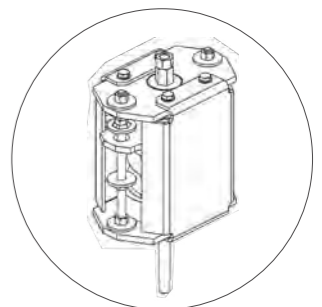

REFERENZE
REFERENCES



HOLY MOSQUE
Mecca - Saudi Arabia



CARRERA PINTO
Atacama - Chile



DATA CENTRE ECMWF
Bologna - Italy



KING ABDULLAH FINANCIAL DISTRICT
Riyadh - Saudi Arabia



NEW DOHA INTERNATIONAL AIRPORT
Doha - Qatar



KAIA AIRPORT
Jeddah - Saudi Arabia

SETTORI
SECTORS



HVAC/R
HVAC/R



INFORMATICO
IT



PETROLIFERO
OIL&GAS



ENERGIE RINNOVABILI
RENEWABLE ENERGY



NUCLEARE
NUCLEAR



MARINO
OFFSHORE



NAVALE
NAVAL

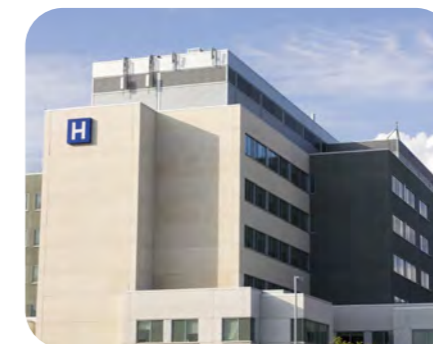

SANITARIO
SANITARY



FERROVIARIO
RAILWAY





www.solecosrl.com | soleco@solecosrl.com

via Masaccio 12, 20096 Pioltello (Mi) | Italy

tel +39 02 92 44 311 | fax +39 02 73 96 50 50 |

cod.fisc. e p. IVA 01349290153 | reg. impr. MI 148283 M.9711244 | R.E.A. MI 835036